

# Installation Instructions

Luminaires must be installed by a qualified electrician. Check with local and national codes for proper installation.



**Never connect a live fixture!!!**

To prevent electrical shock disconnect electrical supply before installation or servicing.

**Never connect a fixture to a live driver!!!**

Contractor is responsible for adequately reinforcing walls and/or ceilings to support fixture weight. Provide blocking when necessary.

## Step 1 - *Open the Box*

Indoor

- a** Unpack Luminaire unit. The Skylum Luminaire consists of (2) major parts: Gear Tray and Housing with Diffuser. Remote Drivers and Housings supplied by Inter-lux.

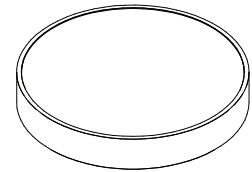

Ø16.1"

Ø410mm

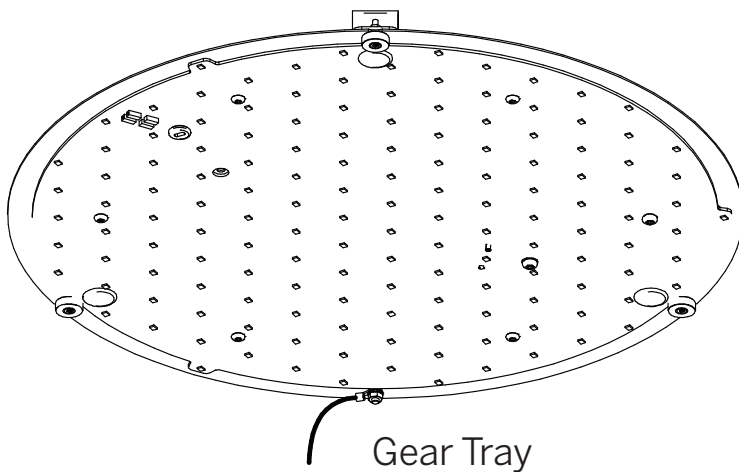

Remote Housing with Driver\*  
(not to scale, generic box shown)

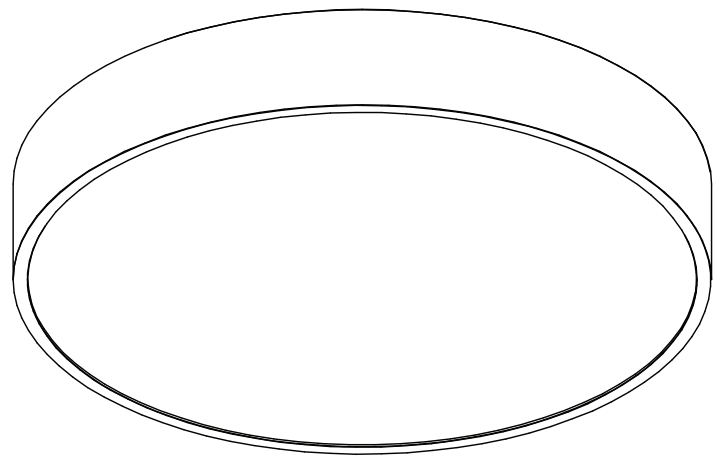
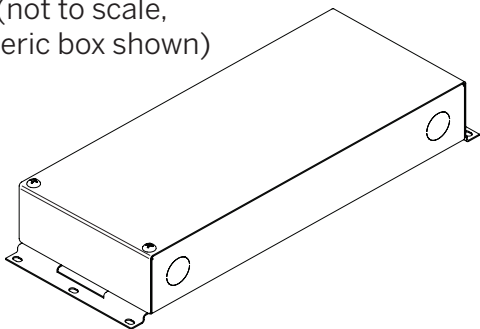

Housing with Diffuser

Need Help?

**NOTE: be careful not to damage the LEDs while installing the Gear Tray !**

Step 2 - **Mounting**

- a** Use supplied template to mark and drill for anchors (by others) on ceiling. Drill additional hole for Power Feed.
- b** Remove Mounting Hole Covers on Gear Tray as indicated below. Set Aside.
- c** Insert Mounting Screws through Mounting Holes to Secure Luminaire against Mounting Bracket.

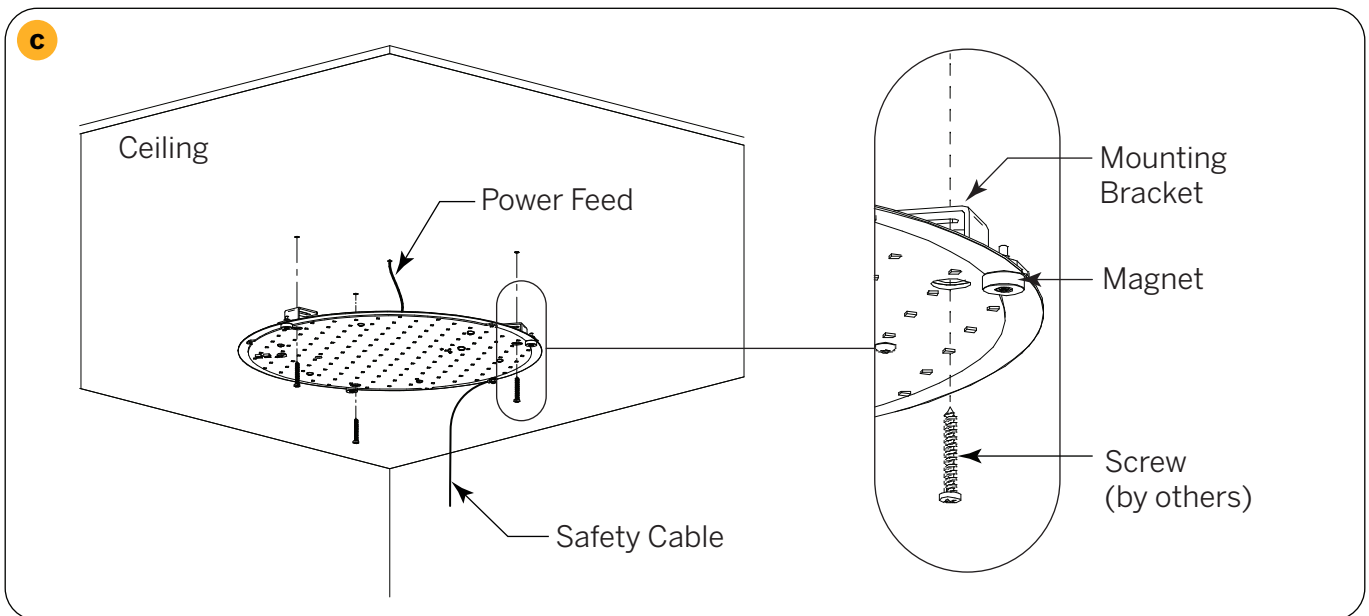
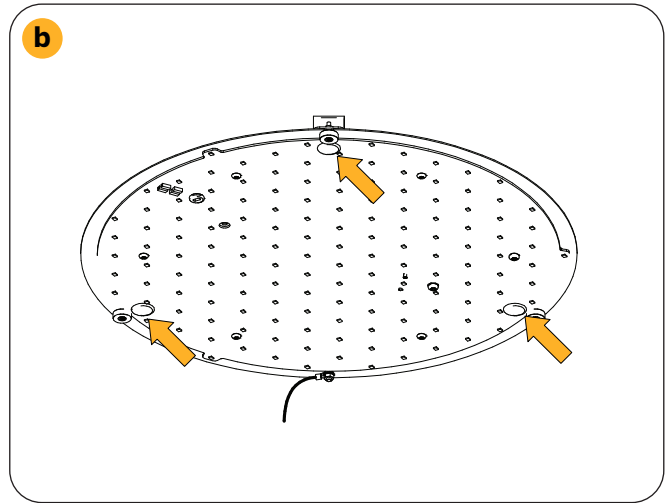
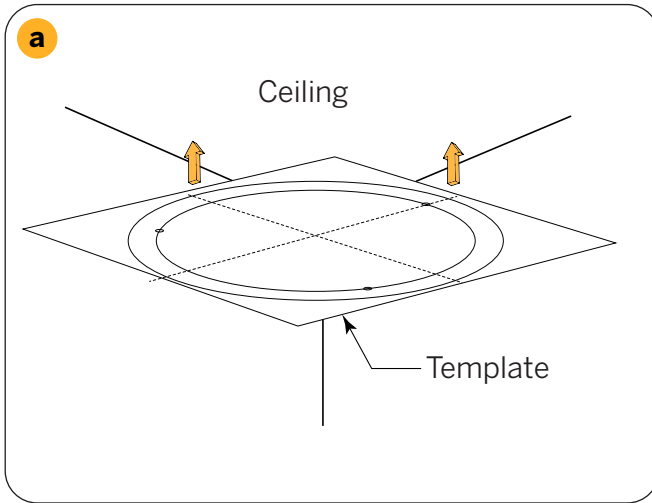

Step 2 - **Continued**

- d** Replace Mounting Hole Covers.
- e** Attach supplied Safety Cable to rim of Housing with included hardware.
- f** Raise Housing toward Gear Tray. Housing mounts to Gear Tray via Magnets adjacent to Mounting Holes.

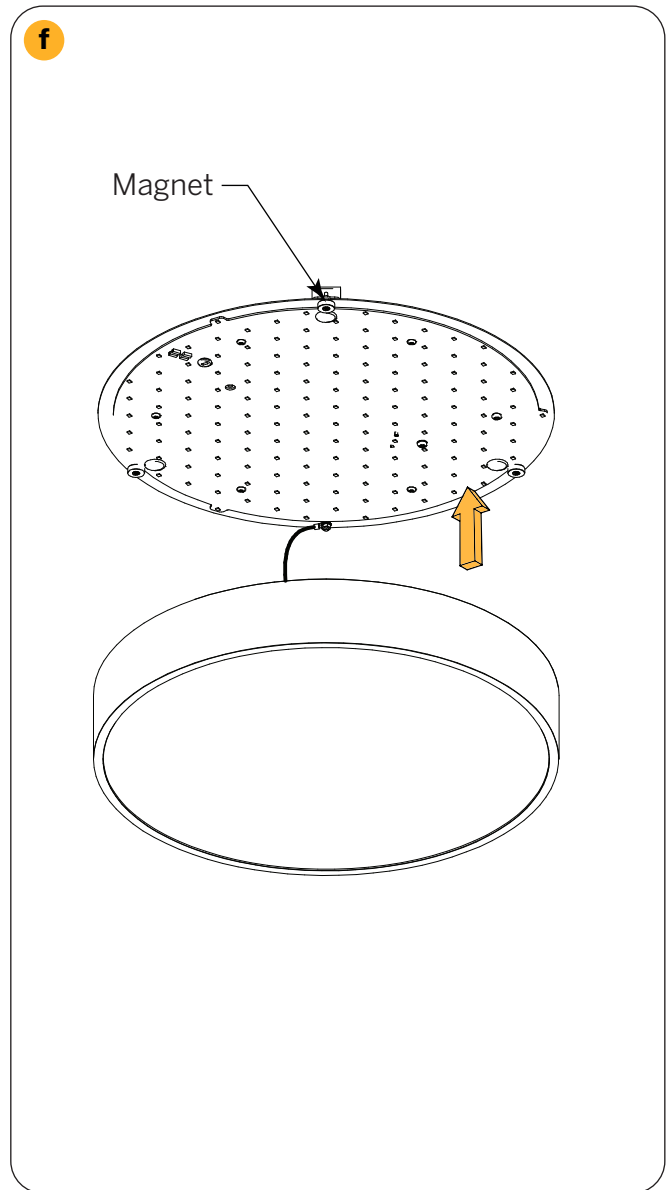
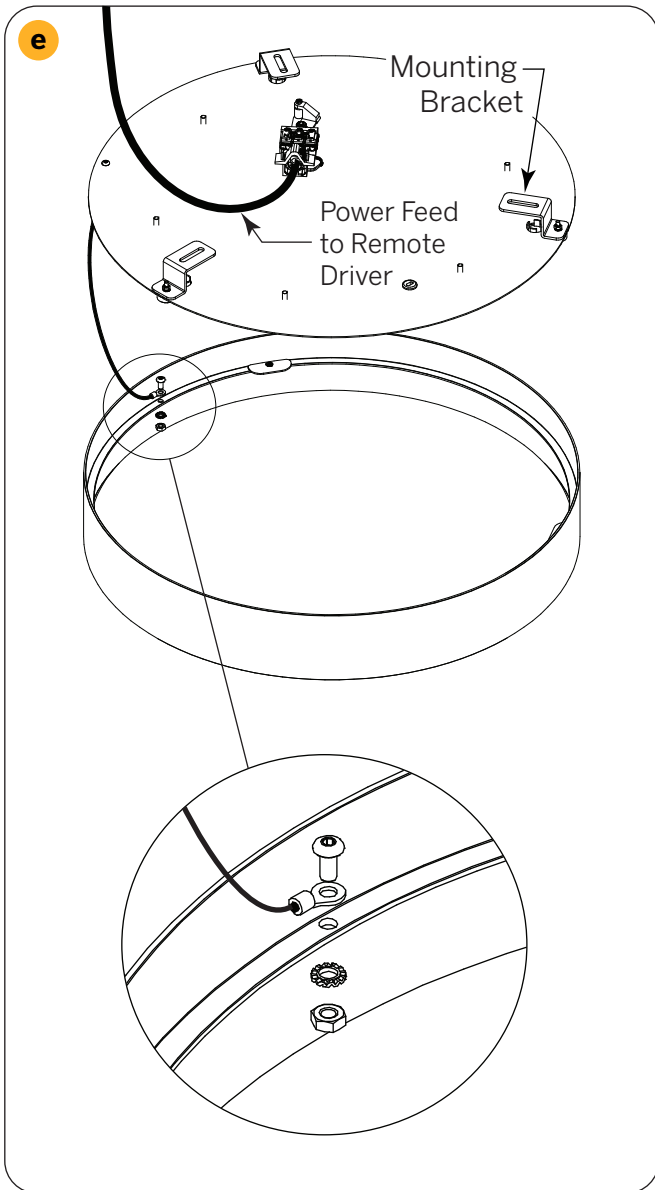

Need  
Help?