

Croc Type X

Mounting

Ground Spike (GS)

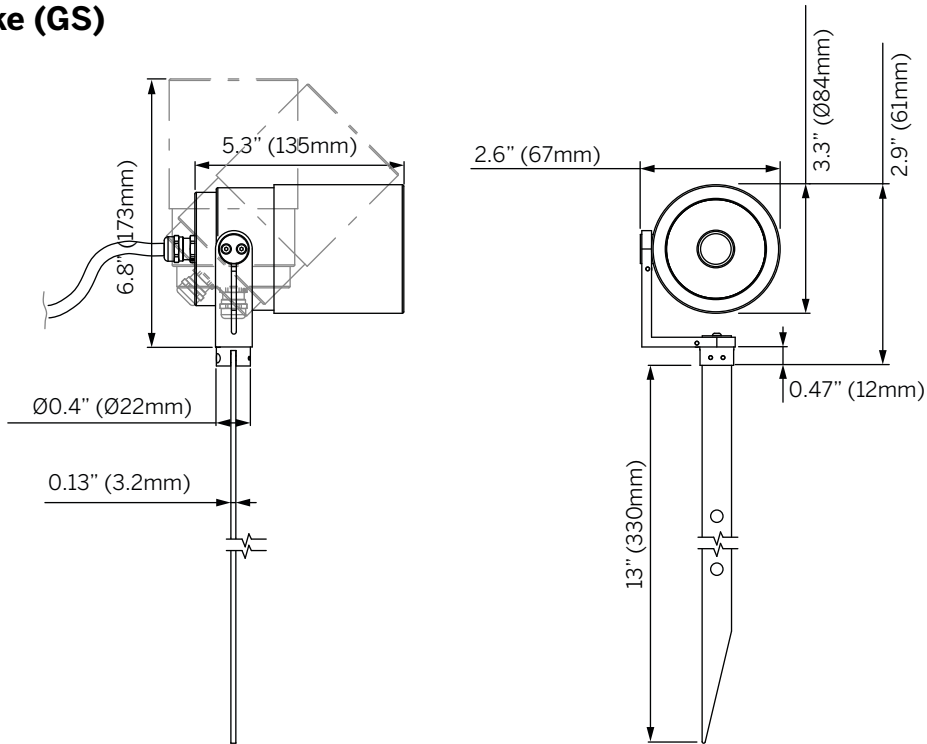

Tree Strap (TS)

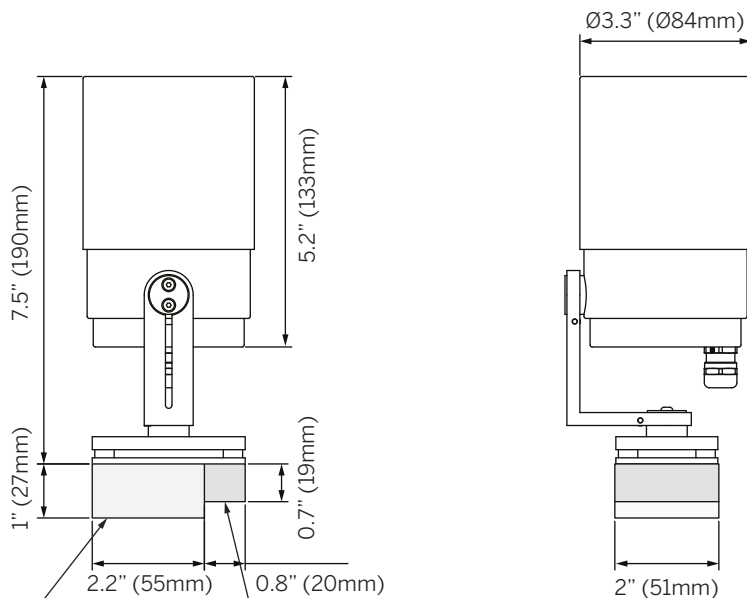

Sponged rubber block to protect tree when fitting is secured.

Hard rubber block to straighten up fitting once attached to tree

Kit supplied with lockable strap suitable for mounting to a tree/trunk measuring Ø8" - 12" (Ø200 - 300mm). The tree strap should be checked and re-adjusted as the tree grows over time.

Accessories

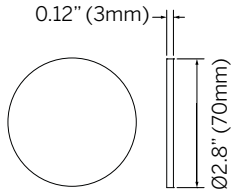

Clear Lens

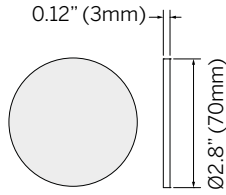

Diffused Lens
(Softens beam)

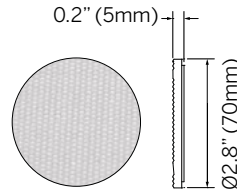

Solite Lens
(Diffuses light)

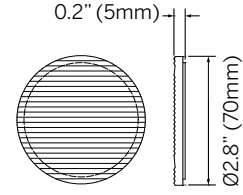

Sharp Spread Lens
(Sharp elliptical beam)

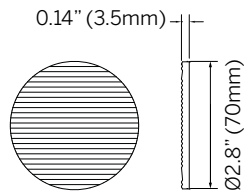

Soft Spread Lens
(Soft elliptical beam)

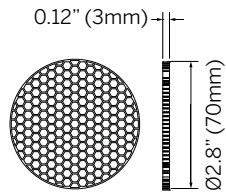

Honeycomb Louver
(Reduces glare)