

# Linear Features



whitegoods



## whitegoods

Whitegoods has developed the most complete range of linear fittings and integration profiles to illuminate any interior space. The Linear range was conceived to apply the right quality and quantity of illumination to the space while minimizing the source of the light and eliminating obtrusive light spill - all while holding true to our brand philosophy:

- Reduction of detail
- Seamless architectural integration
- Logical, modular systems and families of products
- Ease of specification, installation and maintenance

# Linear

Whitegoods is a language of light developed to bring illumination to surfaces in the simplest way possible. We believe in 'luminous surfaces and planes of light'.

It is critical to our approach that our luminaires have a minimal visual impact. Their job is to reveal the surfaces around them, while seamlessly integrating with the architectural envelope. Whitegoods offers the discerning specifier a range of lighting tools to facilitate this approach. The Linear range is the most flexible architectural lighting tool developed to allow designers the freedom to work with light in an instinctive way.

Utilizing the small form factor, the range includes a family of profiles all based around the same high performance linear LED technology, developed by Whitegoods specifically for this product line. Coves, coffers, perimeter wash and seamless lines, all beautifully rendered with smooth even light.

This is Whitegoods: this is Linear.



# Contents

## ProTools 60 Linear

2.4"



ProTools 2.4" Linear Downlight Recessed



ProTools 2.4" Linear Downlight 6" / 12" Recessed

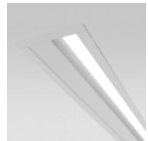

ProTools 2.4" Linear Wall Wash Recessed



ProTools 2.4" Linear Wall Graze Recessed



ProTools 2.4" Linear Perimeter Recessed



ProTools 2.4" Linear Downlight Suspended



ProTools 2.4" Linear Direct/Indirect Suspended



ProTools 2.4" Linear Downlight Surface Mount



ProTools 2.4" Linear Downlight 6" / 12" Surface Mount



ProTools 2.4" Linear Downlight Wall / Mullion Mount

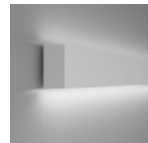

ProTools 2.4" Linear Direct/Indirect Wall / Mullion Mount

## 60 Linear Flush Lens

2.4"



2.4" Linear Recessed Flush Lens



2.4" Linear Suspended Flush Lens



2.4" Linear Direct/Indirect Suspended Flush Lens



2.4" Linear Surface Flush Lens



2.4" Linear Wall Direct or Indirect Flush Lens



2.4" Linear Wall Direct / Indirect Flush Lens

## 100 Linear Flush Lens

4"



4" Linear Recessed Flush Lens



4" Linear Suspended Flush Lens



4" Linear Surface Flush Lens



## Linear

Applications include:

- General illumination
- Wall wash
- Wall graze
- Accent lighting
- Direct/indirect lighting
- Perimeter lighting

Recessed, surface, suspended and wall mounted to any surface type.

The ability to utilize the same form and technology throughout any multipurpose space to deliver a cohesive language of light.

Small scale to integrate invisibly into the architecture, close to the surface being illuminated for greater energy efficiency and minimal spill light.

Specifiable in standard and completely tailored lengths to fit any space.

# Overview

**ProTools 60 Linear** 2.4" aperture family offers straight runs or configurations for linear downlighting, wall washing, wall grazing and perimeter lighting with ultimate performance, superb glare control, lens / louver options and the Whitegoods attention to integration with surrounding materials.

- Recessed
- Suspended
- Surface
- Wall



**60 Linear** 2.4" aperture flush lens family offers straight runs or configurations for linear downlighting with high-angle illumination, lens options and Whitegoods attention to integration with surrounding materials.

- Recessed
- Suspended
- Surface
- Wall

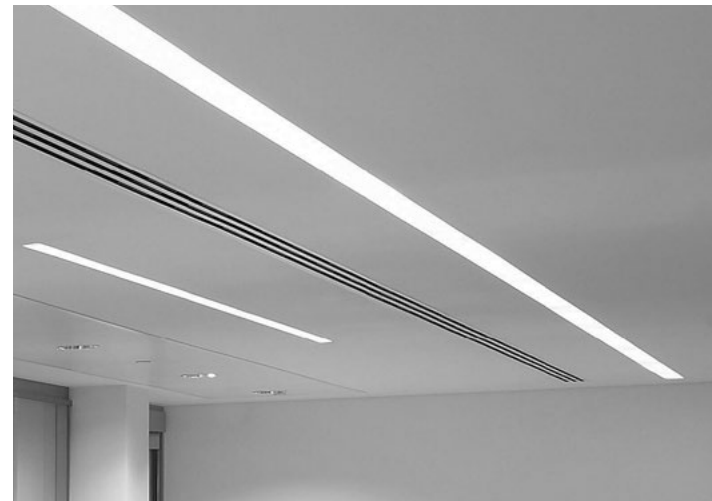

**100 Linear** 4" aperture flush lens family offers straight runs or configurations for linear downlighting with high-angle illumination, lens options and Whitegoods attention to integration with surrounding materials.

- Recessed
- Suspended
- Surface

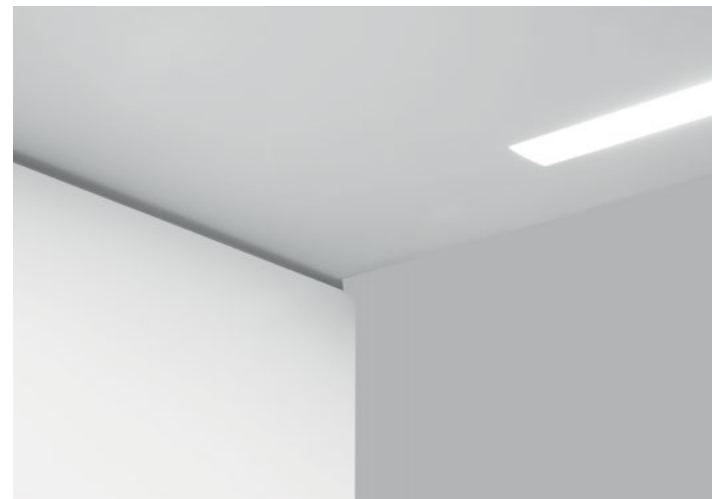

Made in the USA and in stock in Maryland.

# Linear Modularity

Whitegoods utilizes modularity throughout the range to ensure maximum efficiency of design, manufacture and maintenance. For the specifier this means absolute consistency across all product types and applications, as well as making sense economically.

## 60 / 100 Linear Flush Lens

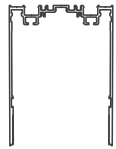

Surface/Recessed Housing



Gear Tray



Diffuser

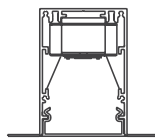

Recessed Plaster Trim

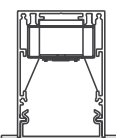

Recessed Bezel/Grid Trim

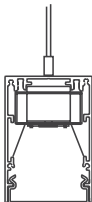

Suspended

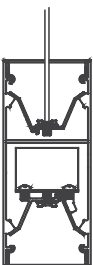

Suspended Direct/Indirect

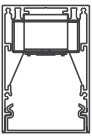

Surface Mount

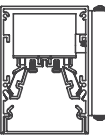

Wall/Mullion Mount

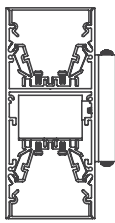

Wall/Mullion Mount Direct/Indirect

## ProTools 60 Linear

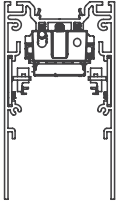

Surface/Recessed Housing

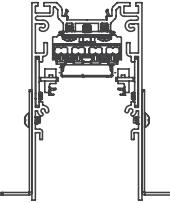

Recessed Plaster Trim

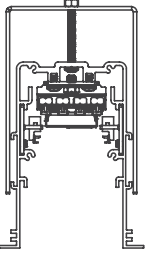

Recessed Bezel Trim

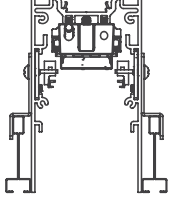

Recessed Grid

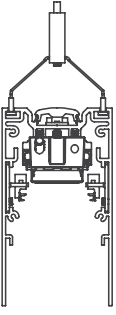

Suspended

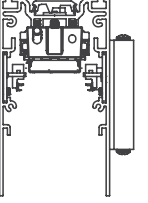

Wall/Mullion Mount

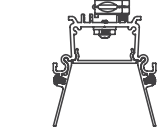

Recessed Micro-prismatic Lens

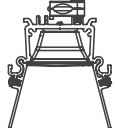

Recessed Louver

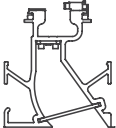

Wall Wash Lens

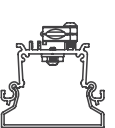

Regressed Opal Lens

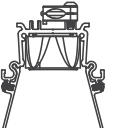

Recessed Narrow Optic

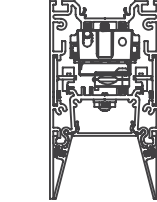

Recessed Micro-prismatic Lens

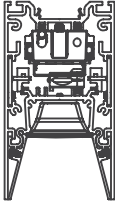

Recessed Louver

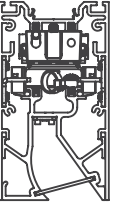

Recessed Lens + Wall Wash

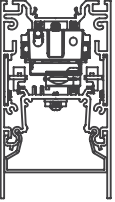

Regressed Opal Lens

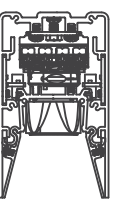

Recessed Narrow Optic



Whitegoods developed a specific LED light source optimized for our linear products, using the highest performance and quality LED devices available on a form factor that best fits our product mechanically and electronically. We use this LED throughout our entire range of 20Linear, Linear, Cove and Perimeter lighting systems. Additionally, we standardize on the highest quality drivers and control devices to ensure that our system works at peak performance and consistency mile after mile.

Whitegoods products are developed in a modular fashion that allows easy repair or replacement of the light source without upsetting the installation. We term this: future proofing.



- Replaceable light source guarantees sustainability.
- Available in any continuous length to accommodate exacting installations.
- Multiple wattages and lumen output for maximum flexibility within any application.
- Constant current, 90+ CRI, 3 step MacAdam.
- Four standard color temperatures from 2700K-4000K + Tunable White (2200K-4000K).
- Compatible with all common dimmer and control standards.
- High efficiency design delivers up to 120 lumens/watt
- L70 (TM21 Projected 85C) 72,000 hours.
- Used throughout Whitegoods 20 Linear, Linear, Cove and Perimeter products for color and performance consistency.
- 5-year warranty.



# Linear System Configuration Logic

Whitegoods Linear systems can be specified to any length and in almost any pattern. Our purpose-designed configuration software determines the exact dimensions required for each and every section. Corners are prefabricated in our factory to keep things simple in the field.

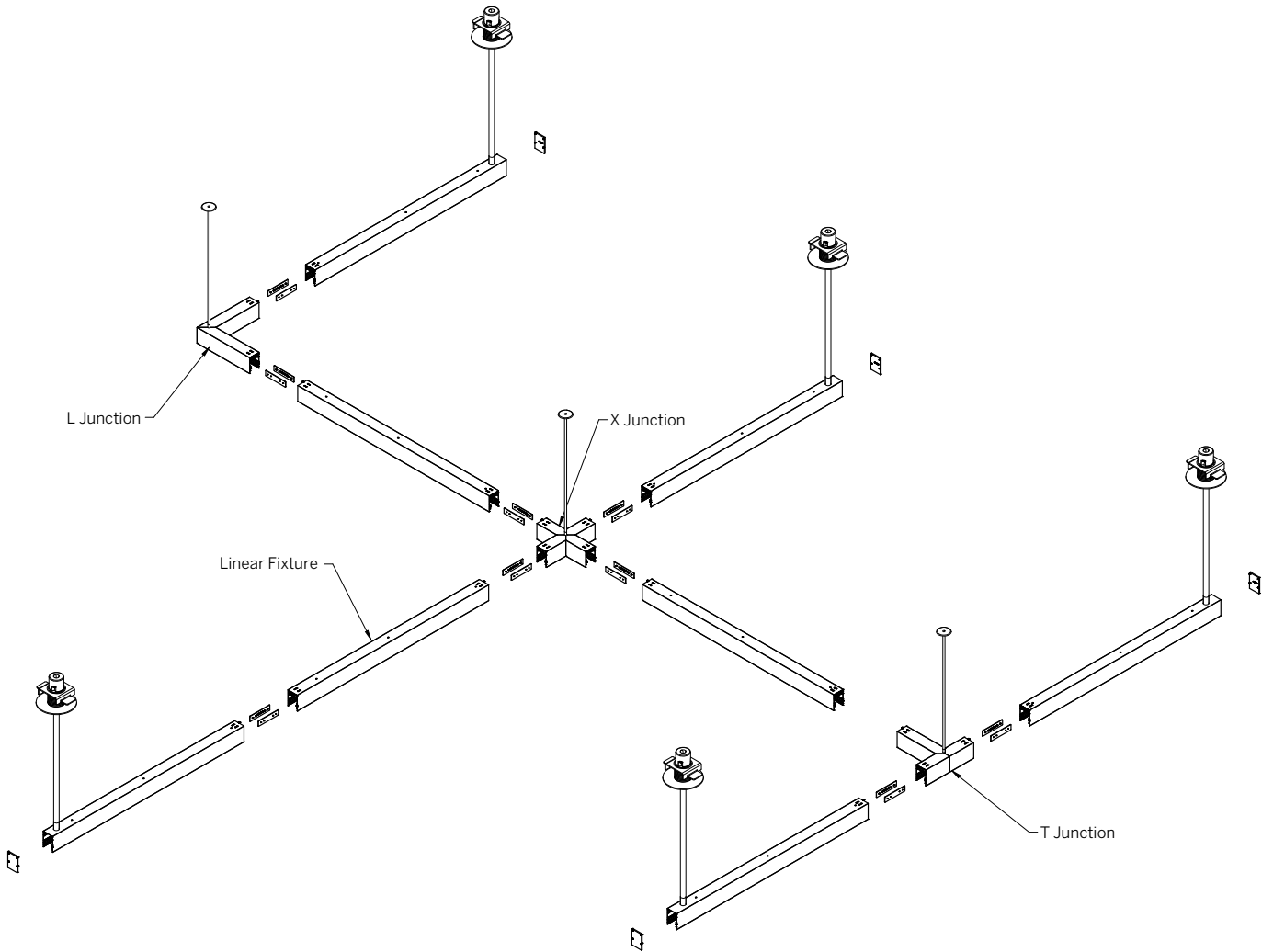



MEMBERS' WALL



# Linear Lenses/Accessories

To further expand the applications that can be successfully achieved with the Linear, Whitegoods continues to develop optical accessories that increase efficiency, tighten the beam spread and shield the light source. The integration profiles available all accommodate optical accessories to allow the designer to combine attributes to successfully satisfy the application at hand.

## Flush Lenses (wide-angle illumination)



Opal Diffuser provides even, continuous line of light and general illumination (OD)



Satin Clear Diffuser for high efficiency soft edge beam, general illumination (SD)



Drop Diffuser of satin acrylic for general illumination and decorative effect (DD)

## Recessed Lenses (multiple distributions and brightness control)



Recessed Micro-prismatic lens - diffusion with maximum efficiency (RML)



Regressed Opal Lens - evenly illuminated line of light (ROL)



Recessed Elliptical Optic - high efficiency graze (REO)



Recessed Louver in white or black - extreme cut-off (RLW/RLB)



Recessed Narrow Optic - narrow beam (RNO)



Linear Micro-prismatic Lens - diffusion and high efficiency (LML)



# Linear Interactive Product Overview

click images to open product pages

### ProTools 60 Linear

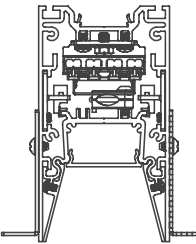
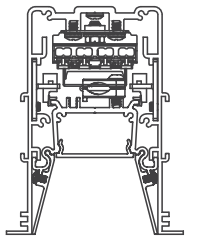
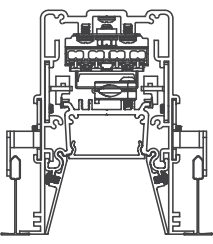
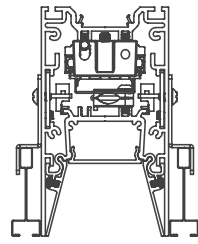
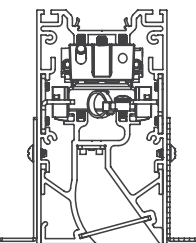
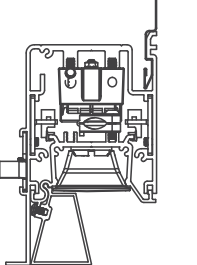
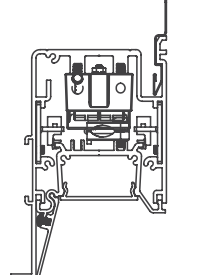
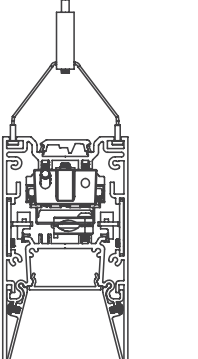
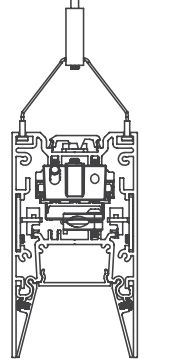
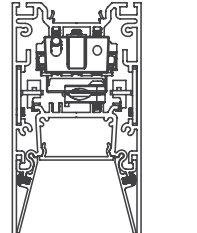
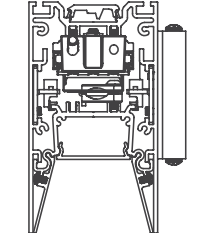
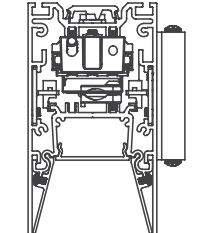



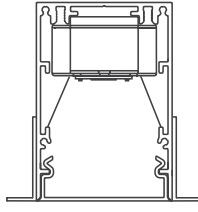
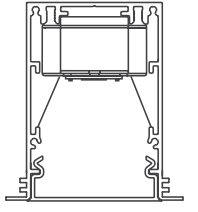
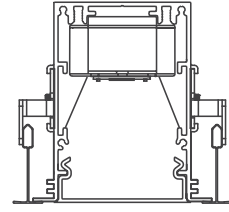
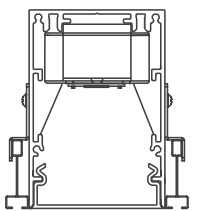
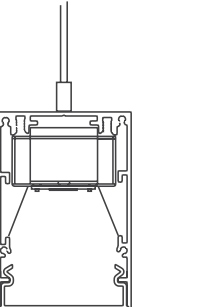
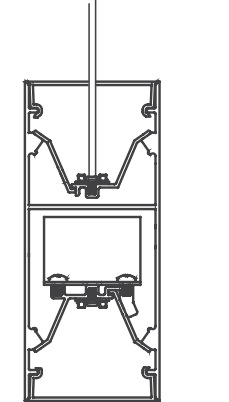
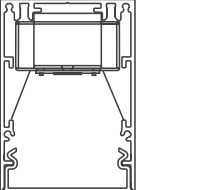
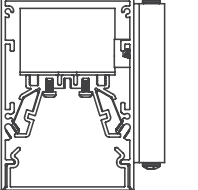
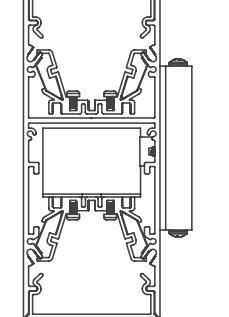

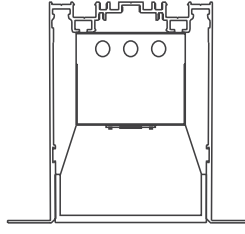
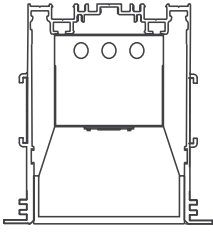
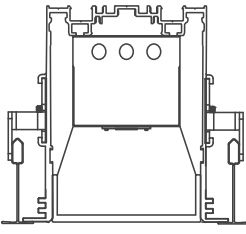
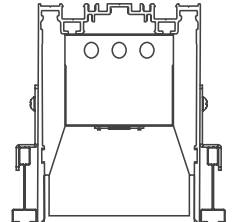
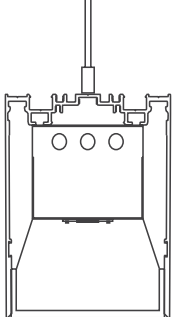
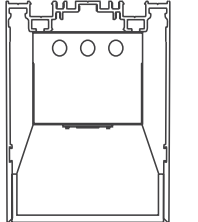

			
<b>60PTL-RPT</b> Recessed Plaster Trim 3-5-7-8	<b>60PTL-RBT</b> Recessed Bezel Trim 3-5-7-8	<b>60PTL-RGT</b> Recessed Grid Trim 3-5-7-8	<b>60PTL-RGTS</b> Recessed Slot Grid 3-5-7-8
			
<b>60PTLWW</b> Recessed Wall Wash 9	<b>60PTLWG</b> Recessed Wall Graze 6-7	<b>60PTLP</b> Recessed Perimeter 3-6-7	<b>60PTL</b> Suspended 3-5-7-8-9
			
<b>60PTLDI</b> Suspended Direct/Indirect 3-5-7-8-9	<b>60PTL-SM</b> Surface Mount 3-5-7-8-9	<b>60PTL-SW/SWM</b> Wall / Mullion Mount 3-5-6-7	<b>60PTLDI-SW/SWM</b> Wall / Mullion Mount Direct/Indirect 3-5-6-7

### 60 Linear Flush Lens

		
<b>60LDL-RPT</b> Recessed Plaster Trim 1-4	<b>60LDL-RBT</b> Recessed Bezel Trim 1-4	<b>60LDL-RGT</b> Recessed Grid Trim 1-4
		
<b>60LDL-RGTS</b> Recessed Slot Grid 1-4	<b>60LDL-S</b> Suspended 1-4	<b>60LDI</b> Suspended Direct / Indirect 1-2-4
		
<b>60LDL-SM</b> Surface Mount 1-4	<b>60LD/LDI-SW/SWM</b> Mullion Mount Direct or Indirect 1-2	<b>60LD/LDI-SW/SWM</b> Mullion Mount Direct / Indirect 1-2

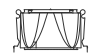
### 100 Linear Flush Lens

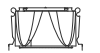
		
<b>100LDL-RPT</b> Recessed Plaster Trim 1	<b>100LDL-RBT</b> Recessed Bezel Trim 1	<b>100LDL-RGT</b> Recessed Grid Trim 1
		
<b>100LDL-RGTS</b> Recessed Slot Grid 1	<b>100LDL</b> Suspended 1	<b>100LDL-SM</b> Surface Mount 1

- |   |   |   |   |   |   |   |   |   |
|---|---|---|---|---|---|---|---|---|
|  |  |  |  |  |  |  |  |  |
| 1 = Opal Diffuser (OD)  | 2 = Satin Diffuser (SD)   | 3 = Recessed Micro-prismatic (RML)  | 4 = Drop Diffuser (DD)  | 5 = Regressed Opal Lens (ROL)   | 6 = Recessed Elliptical Optic (REO)   | 7 = Recessed Louver (RLW/RLB)   | 8 = Recessed Narrow Optic (RNO)   | 9 = Linear Micro-prismatic (LML)  |



## Tunable White

Tunable White allows you to select any color temperature between 2200K and 4000K, while maintaining the same high quality color rendering as the standard LED. This feature is often used in health and wellness applications, as well as work spaces to increase productivity, architectural spaces to match natural light, and for design focus in retail and hospitality environments.

Color Temperature	Description	Typical Usage
4000K	Cool	Office, Exterior
3500K	Neutral Cool	Office
3000K	Neutral Warm	Office, Residential
2700K	Warm: Halogen Incandescent	Residential, Hotel
2200K	Very Warm Incandescent	Residential



## RGBW

The ability to add dynamic color-changing to a very small scale product is an exclusive benefit of LED lighting. When used in conjunction with the 60/100 Linear range, colored light can be introduced into the space for accent, health and mood-setting results.



## Application Guide

Whitegoods Linear products integrate into any space utilizing a multitude of mounting options, and deliver the right illumination where it is intended.

Through the use of multiple optical accessories, Linear products are used for many applications including general illumination of a space, wash of light on vertical surfaces, accent lighting on features and grazing of textured surfaces.

Within the Application Guide, we strive to explain the diversity of applications that can be satisfied with Linear products by breaking those applications into the most common lighting performance categories.

Integration. Versatility.



# Linear Applications

## Downlight

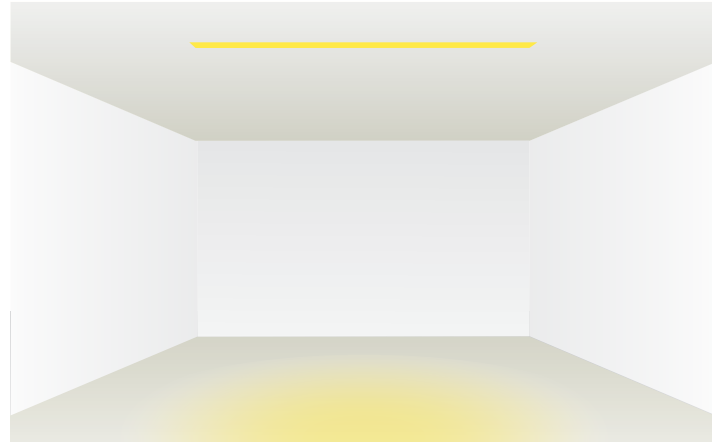

### Regressed Opal Lens

Delivers wide angle general illumination for open spaces such as offices, corridors and classrooms.

### Recessed Micro-prismatic Lens

General illumination with greater brightness control. Spaces where wide angle illumination is required and the source of illumination is not intended as a feature of the space.

### Recessed Louver

This optic delivers narrow to wide angle illumination and a deep recessed louver that eliminates any direct source of brightness. Most applicable for spaces where the object to be illuminated is intended to be the most visible object in the space.

### Flush Opal Lens

Performance includes the highest angle illumination perpendicular to the length of the luminaire while delivering even illumination to the space.

### Flush Microprismatic Lens

Also delivering high angle as well as general illumination, this specially designed lens reduces visual brightness while increasing overall luminaire efficiency.

### Mounting Options

- Recessed in any ceiling type
- Surface mounted
- Suspended
- Wall mounted
- Perimeter mounting

## Wall Wash

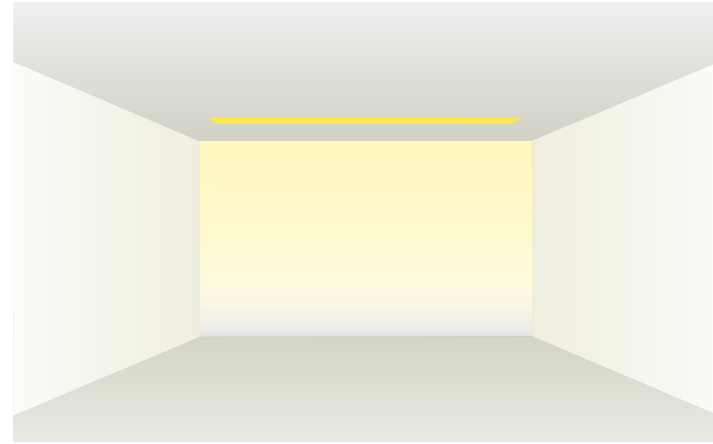

### Linear Wallwash Optic

Spaced appropriately from the wall, accent levels of light are evenly distributed on the subject wall. The wallwash optic delivers light from the very top of the wall, starting with a soft blend of light, to the bottom of the wall evenly, with the maximum light levels found in the mid-wall visual zone. By minimizing the aperture of the luminaire, all brightness from normal viewing angles is eliminated. And with the use of a room-side kicker reflector, all of the light is distributed on the wall without light trespass on the room side. This is all accomplished with a flush to the ceiling plane aperture - the Whitegoods way

### Flush Opal or Micro-prismatic Lens

Often accent levels of light are not needed for a balanced scheme that includes illuminating vertical surfaces. In that case, flush lens Linear will deliver even illumination to adjacent walls by virtue of their soft, high-angle light distribution.

### Mounting Options

- Recessed in any ceiling type
- Surface mounted
- Suspended

## Wall Graze

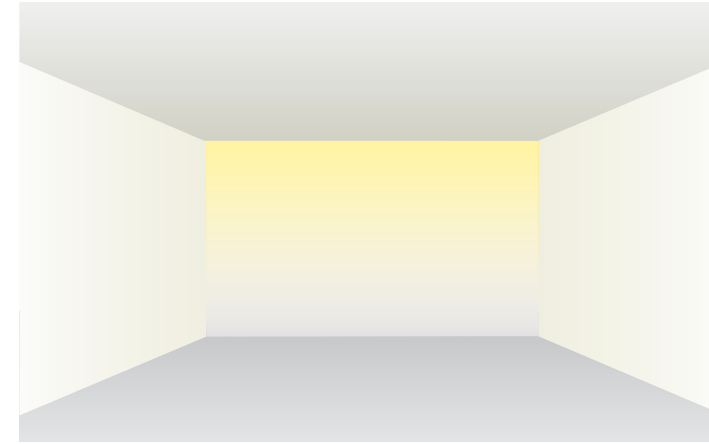

### Perimeter Application

Recessing a continuous linear luminaire at the perimeter of a space is an effective way to provide vertical illuminance that will increase the perceived brightness of the space. The wall side flange of the fixture is removed which allows the wall to continue past the ceiling plane, seemingly to infinity.

### Recessed Louver

By adding a tighter beam of light to the wall graze distribution, light is driven further down the wall and delivers a sheet of light from above the finished ceiling to the base of the wall. The recessed louver cuts viewing angles to the light source when viewed from any angle, and the choice of low or no brightness finishes on the wall-side reflector ensures that the wall is the brightest object in the space.

### Soft-Graze

This feature simply extends the optic further from the wall and softens the contrast effect on the wall. All texture or imperfections of the wall will be less noticeable while you still have the option of using this fine grazing light.

### Recessed Elliptical Optic

The recessed elliptical optic has a very similar light distribution to that of the Recessed Louver versions but will provide 30% more lumens to allow for use in taller ceiling height applications.

### Mounting Options

- Recessed in any ceiling type
- Perimeter mounting

## Perimeter

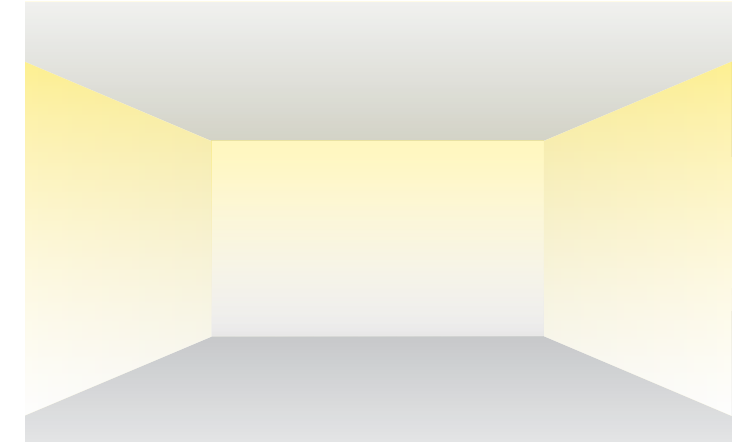

### Recessed Micro-prismatic Lens

A continuous perimeter lighting system that delivers an even wash of light at the top of the wall, from above the finished ceiling, and gradually diminishes closer to the floor. The Perimeter system can be used to illuminate corridors and provide definition to feature walls.

### Recessed Louver

Adding narrow beam optics and a deeply recessed louver in the perimeter system can deliver high levels of light to accent a wall feature up to 30 feet high, and illuminate objects below such as furniture or plant walls, while minimizing glare.

### Soft-Graze

This feature simply extends the optic further from the wall, softens the contrast effect on the wall and projects more light to horizontal surfaces and features on the floor below. In addition, it can compensate for feature wall thickness and put the light exactly where it is needed.

### Mounting Options

- Recessed in any ceiling type
- Perimeter mounting



## Indirect

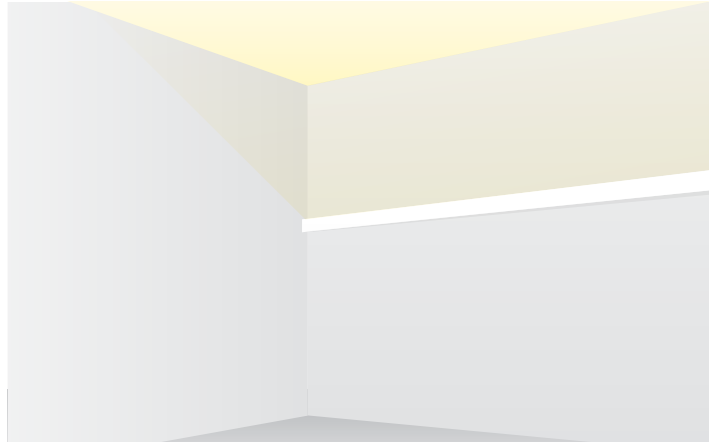

### Batwing

ProTools 60 Linear uplight optics are accomplished through high efficiency refractor lenses specially designed for our LED boards. The Batwing is the wide angle lens that also delivers an even level of light directly above the luminaire. Use this lens when you are as close to the ceiling as 6 inches, use low power LED and still get light out into the space. Typical distances from the ceiling would be 12 inches and more for higher light output.

### Asymmetric

The asymmetric lens is used to direct the majority of the light to one direction. Using this uplight option in a wall mount luminaire will put much less light on the wall and more into the space being illuminated.

### Diffuse Opal Lens or Clear Satin

In applications where the luminaire may be viewed from above, or the application simply calls for general, diffuse illumination, an opal or clear satin lens will obscure the LED pattern and deliver diffuse light to the surface above.

### Mounting Options

- Suspended
- Wall Mount

## Direct/Indirect

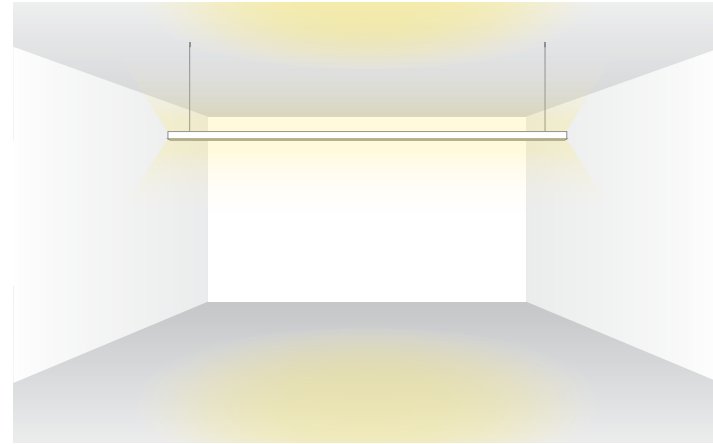

### Direct Light

The downlight component of any Direct/Indirect luminaire utilizes the same optical inserts, thus the same optics as previously referenced under: Downlight.

### Indirect Light

The uplight component of any Direct/Indirect luminaire utilizes the same optical inserts, thus the same optics as previously referenced under: Indirect.

### Mounting Options

- Suspended
- Wall Mount

## Configurations

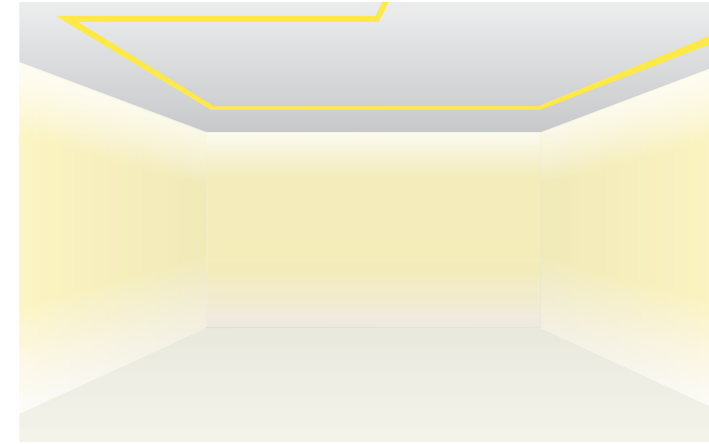

### Configurations

All Linear products are capable of being combined to produce continuous runs of any length. Our Housings can be produced to exact dimensions, the illuminated lenses (Regressed and Recessed) can fill the entire housing with light. Only the Recessed Louver has practical length limitations and cannot accommodate any length - so the LED/louver is provided in 6 inch increments and the difference is filled with a recessed snap-in cover and evenly applied to both ends of a run. Of course we can customize that. We provide corners in 90 degree standard as well as custom. In the same plane, or in two planes such as wall-to-ceiling and wall-to-wall.

Standard or Tailored - the Whitegoods way.

### Mounting Options

- Recessed
- Surface Mount
- Suspended
- Wall Mount
- Perimeter

## Combinations



### Combinations

Some applications call for multiple light distributions within a continuous channel. ProTools 60 Linear has been designed in such a modular fashion, so we can populate the housings with different optical inserts - even in a single luminaire or run of multiple luminaires. As long as you specify in minimum 24 inch lengths, we can accommodate your space with a multiple function linear solution.

A Combination is appropriate in spaces where a clean, low brightness, continuous appearance in combination with different lighting applications are required, such as retail, conference rooms and lobbies.

Modularity and Flexibility. Challenge us..

### Mounting Options

- Recessed
- Surface Mount
- Suspended
- Wall Mount



SPINY DOGFISH CAFE

coffee

hello Goodness

hello Goodness





## Integration

**Balancing the** natural light within the space, continuous linear recessed luminaires are mounted directly opposite the clerestory north lights. As daylight fades the luminaires fade in to provide enough ambient light to the gallery space. The light in effect still comes from the same position, mimicking the natural light effect.

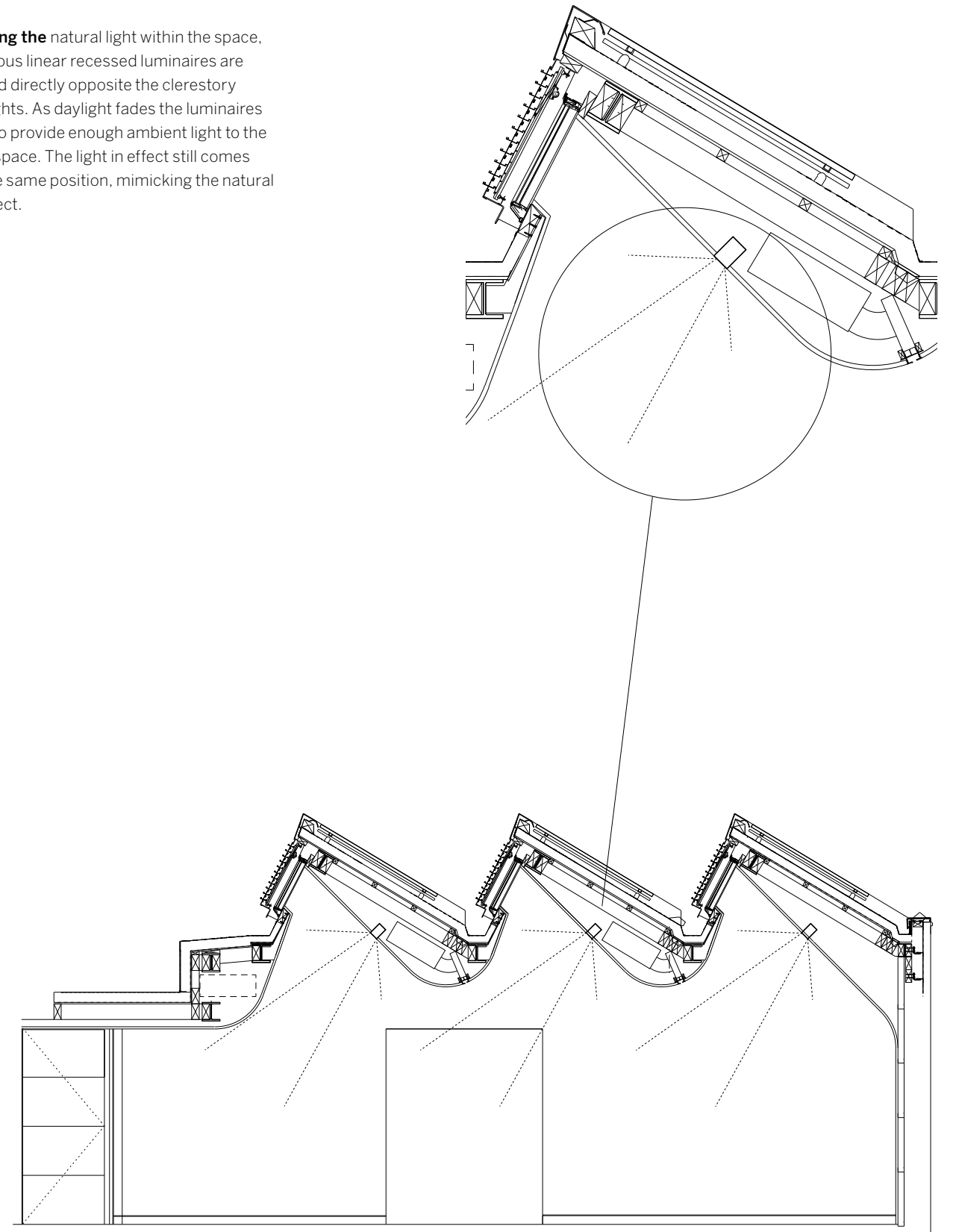

## Suspended Configurations

Linear configurations can take many shapes, sizes and patterns. Designed for nearly any mounting option, coupled with unlimited length and corner possibilities, the designer's only limitation is the space where the product will live.

Here overlapping rectangles are suspended to illuminate a reading space day and night through a combination of direct and indirect light set to appropriate levels and maintained by an ambient light sensor attached to the control gear. Additionally, the system is designed to provide a portion of the required light levels for the feature grow wall.

The system is mechanically held together by active tension cross joiners that apply constant force to fixture connections eliminating light leak. The suspensions are located most anywhere along the system to minimize the clutter and afford the designer maximum freedom.

Modularity + Flexibility + Design

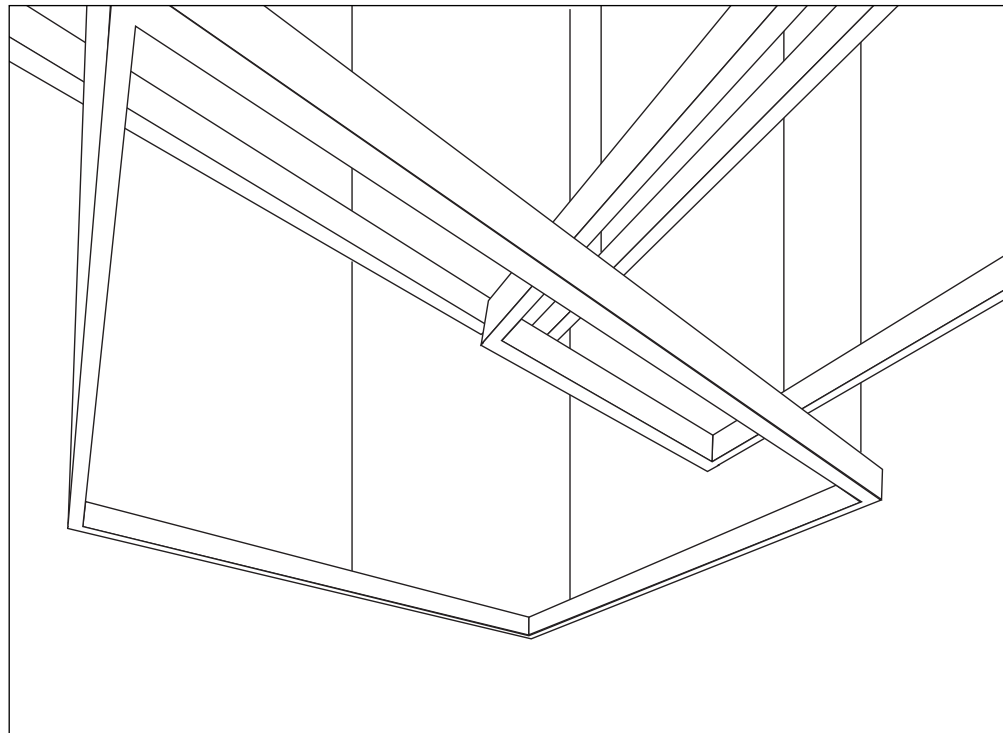



## Clear Span Solution

**Balancing the** natural light within the space, continuous linear surface mounted luminaires are mounted directly beneath the skylights. As daylight fades the luminaires fade in to provide enough ambient light to the library space. The light in effect still comes from the same position, mimicking the natural light effect.

Without a solid ceiling above to anchor the fixture runs, a stiffener was developed to maintain rigidity across the clear-span. And the standard end-wall detail was applied to provide mechanical and electrical service to the system.

WOW

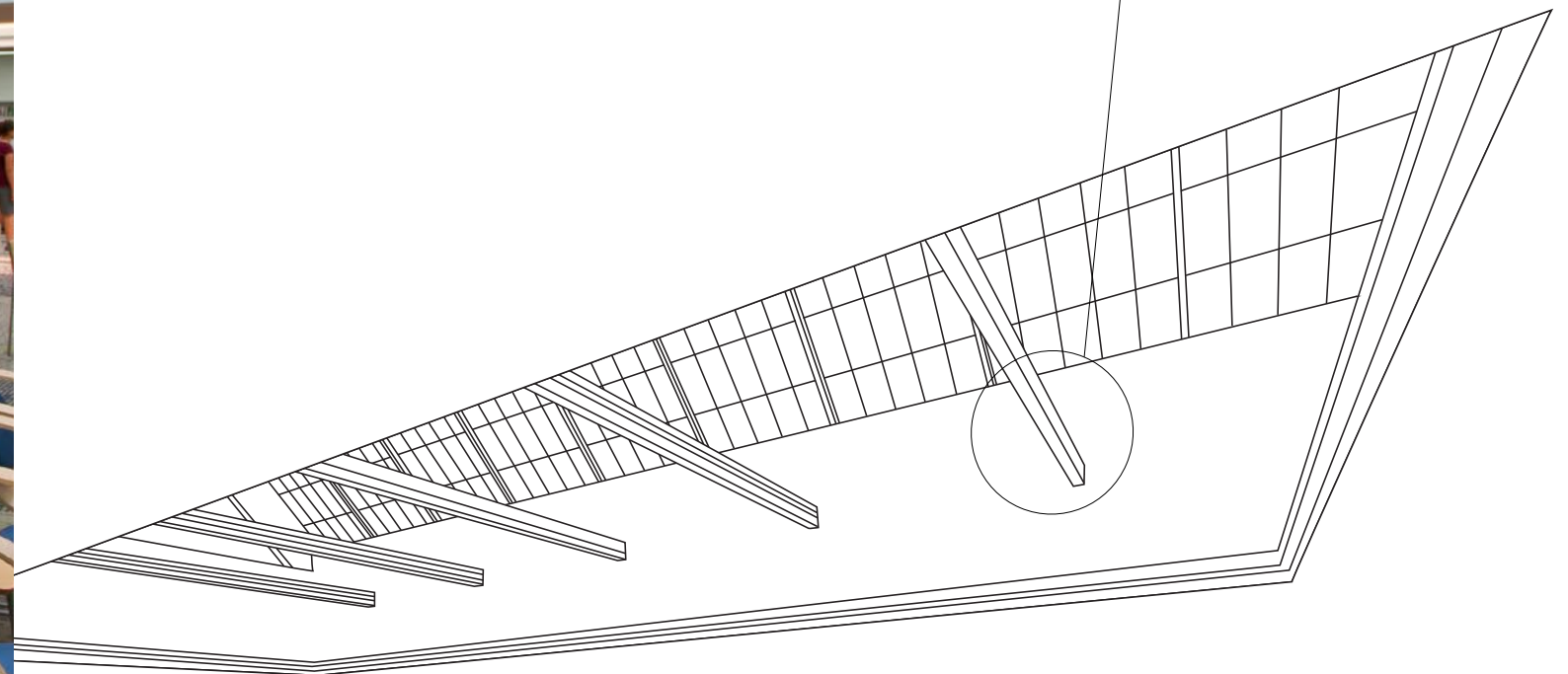
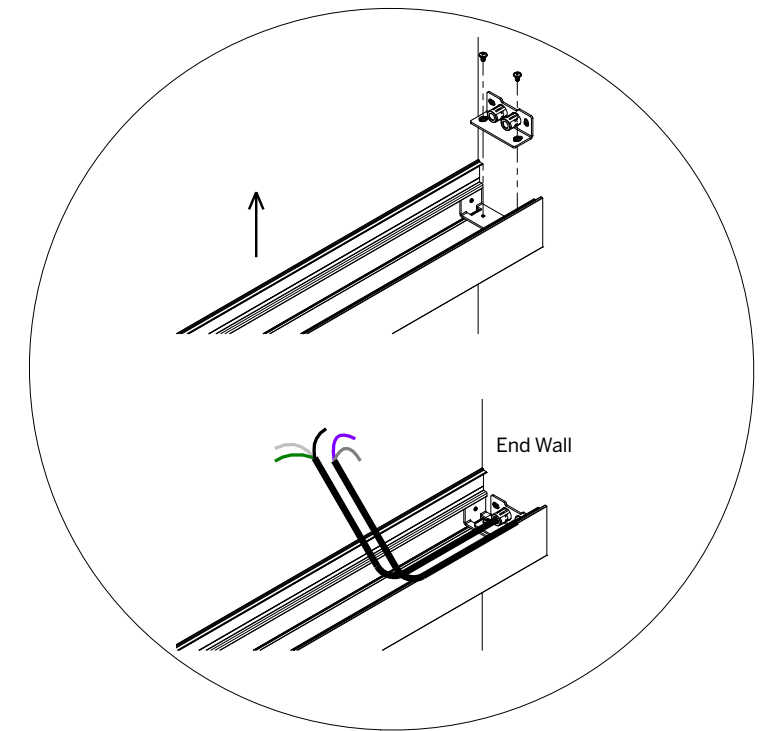



## Recessed Configurations

Whitegoods products have been designed to be 'tailored' to suit the needs of architects and designers seeking to use light as an integrated architectural element.

In this case, our 100 Linear luminaire (100LDL) has been integrated into a wood finish wall paneling system, and then transitions seamlessly via a factory prefabricated corner section into a gypsum ceiling surface. As if this were not enough, the luminaire is completely trimless by way of the Plaster Trim. The lens is continuous and evenly illuminated with no shadows or gaps apparent to the viewer, who perceives only the light, rather than the luminaires used to deliver it.

Whitegoods: Reduction of detail, and seamless architectural integration.

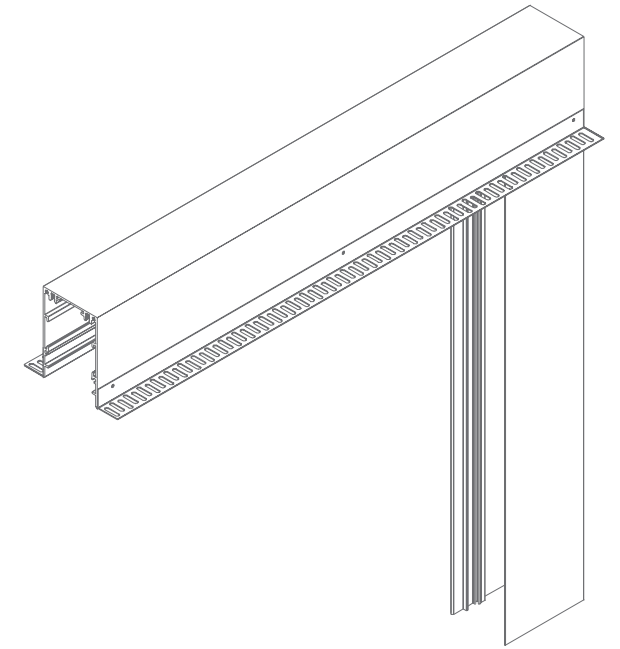

Section View of Ceiling Integration

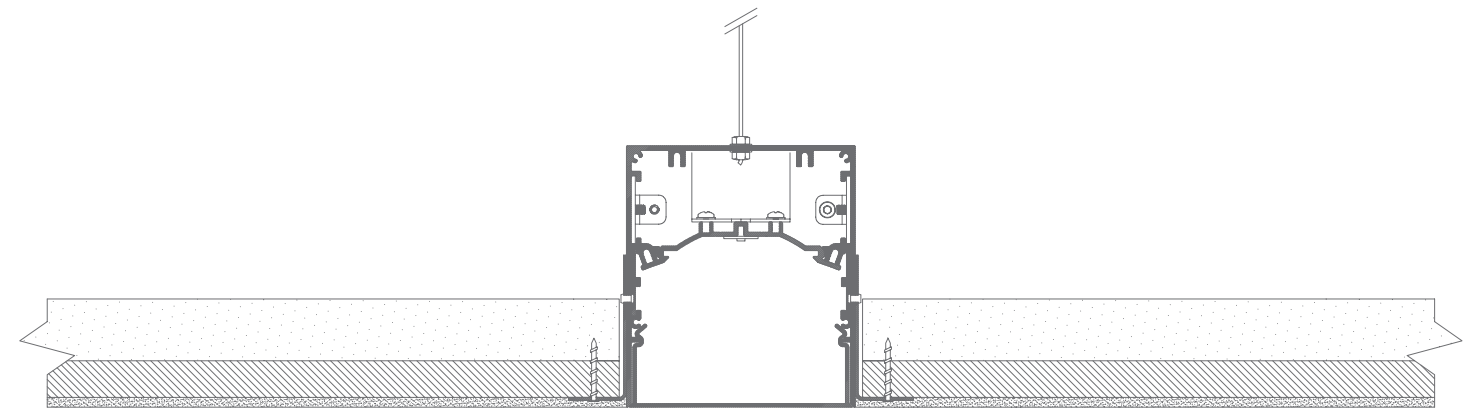

Plan View of Wall System Integration

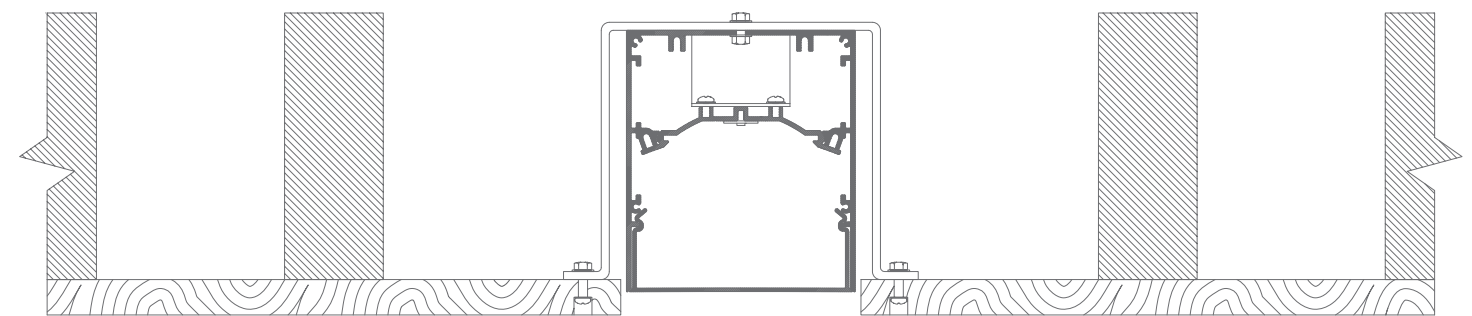

# Ease of specification

### 60 Linear Recessed Flush Lens

Model	Fixation	Pattern	Length	Power <sup>2</sup>	CRI/ CCT <sup>3</sup>	Driver <sup>5</sup>	Lens	Finish <sup>7</sup>	Options
WG-60LDL	RPT RBT RGT9 RGT15 RGTS	S P1 <sup>1</sup> PPI <sup>1</sup> PPO <sup>1</sup> PZ <sup>1</sup>	A A x B A x B x C A x B x A x B	P1 P2 P3 P4 M	927 930 935 940 TW <sup>4</sup> RGBW	E1 L1 LOE BT DALI TQ DMX	OD (std) DD <sup>6</sup>	W (std) B S F	CP EM NYC

## Catalog Page

### 60 Linear Recessed Flush Lens

- 2.4" aperture, integrated solution that is compatible with all ceiling types
- Standard and tailored run lengths, including corners, wall-to-wall and wall-to-ceiling configurations
- Flush lens for wide angle, even illumination
- Multiple control and connectivity options
- Consistent LED technology used throughout the Whitegoods product range
- Flexible design allows for installation from below with separate housing and gear tray for ease of installation and maintenance
- Flicker-free full range dimming with standard driver (Eldoled)
- Manufactured in the USA

**Housing**  
Precision extruded aluminum for true dimensions and tolerances  
Snap-in flush lens for seamless integrated appearance  
Standard and tailored lengths including corners, wall-to-wall and wall-to-ceiling configurations  
Finishes: white, black, silver and custom

**Integration**  
Fixation onto any surface such as gypsum, hard ceilings and all grid ceiling types

**Distribution**  
High angle illumination linear downlight

**LED**  
>90 CRI, 3-Step MacAdam, 2700-4000K static white  
3W-15W per foot, 380 nominal lumens per watt average, constant current  
Tunable white 2200-4000K, 80 nominal lumens per watt average  
RGBW, 50 nominal lumens per watt  
L70 (TM21 Projected IES) Static White / Tunable White = 72,000 hours, RGBW = 50,000 hours

**Optic**  
OD - Snap-in flush satin opal acrylic for even illumination  
DD - Snap-in 1" drop diffuser for wide distribution

**Driver**  
Compatible with quality constant current drivers

**Connectivity**  
POE  
Wireless

**Weight**  
4lbs per foot

**Operating Temp**  
Suitable for operation in maximum ambient temperature of 35C (95F)

**Warranty**  
5-year Limited (see complete company warranty information)

**Certifications**  
ETL and ETL-C for dry and damp location, CE, Chicago plenum

**Voltages**  
120-277VAC

**Lenses/Accessories**

82 Whitegoods Linear

### 60 Linear Recessed Flush Lens

Model	Fixation	Pattern	Length	Power <sup>2</sup>	CRI/ CCT <sup>3</sup>	Driver <sup>5</sup>	Lens	Finish <sup>7</sup>	Options
WG-60LDL	RPT RBT RGT9 RGT15 RGTS	S P1 <sup>1</sup> PPI <sup>1</sup> PPO <sup>1</sup> PZ <sup>1</sup>	A A x B A x B x C A x B x A x B	P1 P2 P3 P4 M	927 930 935 940 TW <sup>4</sup> RGBW	E1 L1 LOE BT DALI TQ DMX	OD (std) DD <sup>6</sup>	W (std) B S F	CP EM NYC

**Model**  
WG-60LDL = 60 Linear Recessed Downlight

**Fixation**  
RPT = Recessed plaster trim  
RBT = Recessed bezel trim for hard ceiling  
RGT9 = Recessed trim for 9/16" grid  
RGT15 = Recessed trim for 15/16" grid  
RGTS = Recessed grid trim slot

**Pattern**  
S = Straight run  
P = Standard patterns 2, 3 or 4 sided with 90° corners on the same plane!  
PPI = Wall to ceiling / wall to wall, 90° inside corner!  
PPO = Wall to ceiling / wall to wall, 90° outside corner!  
PZ = Non-standard patterns and/or corners other than 90° on multiple planes, consult factory!

**Length**  
A, B, C = specify inches to the nearest 0.25" (i.e. 72.25"). For patterns specify each length (i.e. 2 sided: A x B = 72.25" x 48"; 3 sided: A x B x C; 4 sided: A x B x A x B).

**Power<sup>2</sup>**  
P1 = 3W/ft  
P2 = 6W/ft  
P3 = 10W/ft  
P4 = 15W/ft  
M = 7.6W/ft (RGBW Only)

**CRI/CCT (90+ CRI)**  
927 = 2700K  
930 = 3000K  
935 = 3500K  
940 = 4000K  
TW = Tunable white 2200-4000K  
RGBW = 3000K White

**Driver (Integrat<sup>5</sup>)**  
E1 = EldoLED 0.1% dimming, 0.10V (120-277V)  
L1 = Lutron 2% dimming, Ecosystem (120-277V)  
PoE = Power over Ethernet  
BT = Wireless CAS - Casambi (Must specify BT with E1 or DALI)  
DALI = EldoLED Dali DT8 0.1% (120-277V) (Tunable white ONLY)  
TQ = T-Series for Lutron Quantum 0.1% (120-277V) (Tunable white ONLY)  
DMX = Custom-EldoLED, 24V, DMX Dimming (RGBW ONLY)

**Lens**  
OD = Satin opal diffuser (standard diffuse)  
DD = Drop diffuser

**Finish<sup>7</sup>**  
W = White, 15% gloss, RAL 9010 / Tiger Drylac 009/10120 (standard)  
B = Black, 15% gloss, RAL 9005 / Tiger Drylac 044/90053  
S = Silver, 15% gloss, RAL 9006 / Tiger Drylac 040/90050  
F = Custom finished trim, specify RAL

**Options**  
CP = Chicago plenum  
EM = Emergency LED driver (remote only)  
NYC = 6' whip per run

Whitegoods reserves the right to change any information without prior notice.

**Notes**  
1. See pattern spec sheet  
2. Voltage shown does not include power supplies/drivers  
3. See spec page for detailed lumens  
4. TW only available with P2 and P3  
5. See power supply page for details  
6. Built beam lenses when in continuous run, straight runs only  
7. See Tiger Drylac color chart: inter-lux.com/tiger

Technical information  
inter-lux.com/whitegoods 83

## Website Product Page

---

### 60 Linear Recessed Flush Lens

**A continuous flush lens recessed linear luminaire with absolute minimal visual impact**

- 2.4" aperture, integrated solution that is compatible with all ceiling types
- Standard and tailored run lengths, including corners, wall-to-wall and wall-to-ceiling configurations
- Flush lens for wide angle, even illumination
- Multiple control and connectivity options
- Consistent LED technology used throughout the Whitegoods product range
- Flexible design allows for installation from below with separate housing and gear tray for ease of installation and maintenance
- Flicker-free full range dimming with standard driver (Eldoled)
- Manufactured in the USA

Gallery
Specify
Learn More
Installation
IES / 3D Drawings

Download All
Download Selected
Selections download as one PDF

Spec Page

Photometry

CCT.3 Static White LED

CCT.3 Tunable White LED

Constant Current + RGBW (CV)

Constant Current Emergency

Patterns

#### Related Products

60 Linear Surface  
2.4" Surface, Direct

60 Linear Suspended  
2.4" Pendant, Direct

60 Linear Suspended  
2.4" Direct / Indirect

60 Linear Wall  
Mount  
2.4" Direct / Indirect

60 Linear Wall  
Mount  
2.4" Direct or Indirect

The application of light to the surfaces around us is a critical factor in our perception of any space.

When proper consideration is given to the architecture, function and the desired atmosphere, lighting can become a truly integrated part of the overall environment being created, often unseen although defining and enhancing the space.