

INFORMAZIONI TECNICHE - TECHNICAL INFORMATION

Rated voltage	See product list table
Frequency	50/60Hz
Insulation class	See product list table
Ambient temperature	-20°C ÷ +50°C
Power	See product list table

Installazione / Manutenzione - Installation / Maintenance

The item must be installed by qualified personnel, **in accordance with the installation regulations in force in the country in question**; in case of ceiling light malfunction or need for maintenance contact LINEA LIGHT customer service:

support@linealight.com.

IT IS FORBIDDEN TO OPEN/TOUCH THE ITEM WHILE IT IS IN OPERATION;

If the indicated rules are not respected, **the LINEA LIGHT company declines any type of responsibility.**

S1 Screws and Dowels **INCLUDED.**

S2 Screwdriver and hexagonal spanner **NOT INCLUDED.**

APPROPRIATE USE:

The appliance is guaranteed only if the item in question has been installed following the instructions given in this instruction manual and from the general one inside the packaging and/or downloadable from our website

www.linealight.com;

Improper use of the fixture may affect the lamp life and/or may have premature failure.

For further warnings and explanation of any symbols, see the general instruction sheet.

Keep these instructions for future installation/maintenance work.

SERIES: D-WAVE
BRAND: i-LèD
LIST OF FIXTURES

CODE	L Inch (mm)	WEIGHT
E77407	78.7" (2000mm)	11.7 lbs.

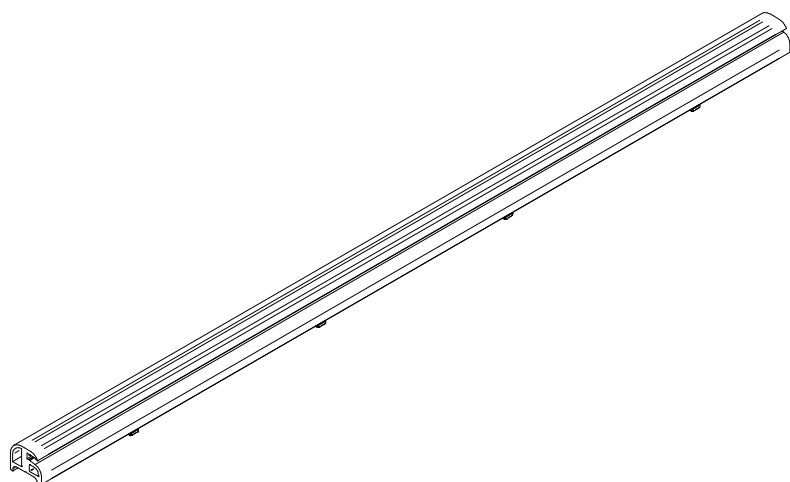

ACCESSORIES INCLUDED:

A. Quick release bracket
(4x included per module)

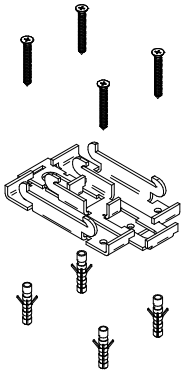

ACCESSORIES NOT INCLUDED:

B. Right end cap

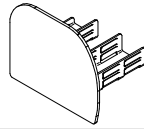

C. Left end cap

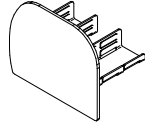

D. Straight Joiner

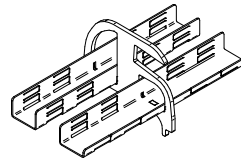

E. Soft ground spike

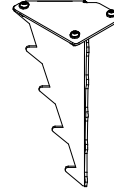

F. 90° Inside corner joiner

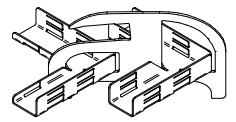

G. 90° Outside corner joiner

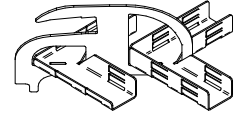

DIMENSIONS

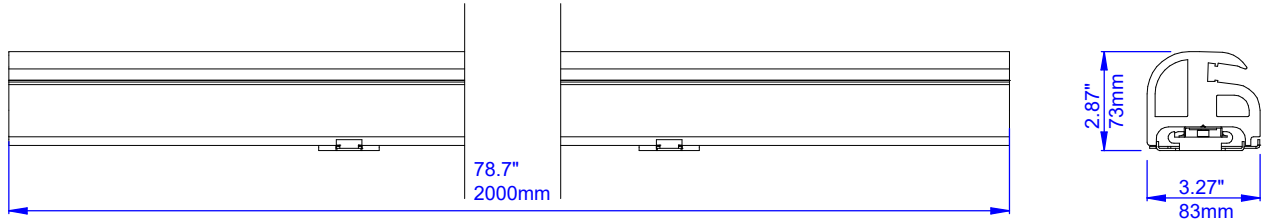

PRE-INSTALLATION



IT IS POSSIBLE TO CUT THE PROFILE TO THE DESIRED LENGTH

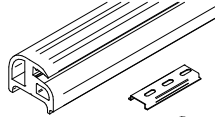

1

FIX THE BRACKETS USING SCREWS POSITIONED ON THE NOTCHED PART OF THE PROFILE. THE SCREWS MUST BE PLACED AS FAR FROM EACH OTHER

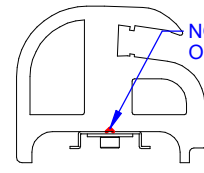
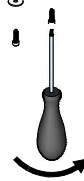

NOTCHED PART OF THE PROFILE

RECOMMENDED SPACING

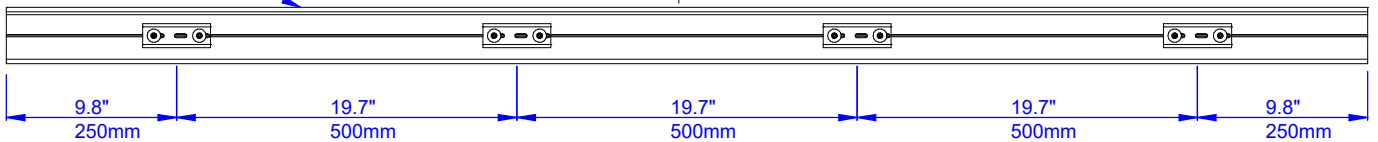

2.a

FIX THE BRACKETS TO THE GROUND. PAY ATTENTION TO THE STEP SELECTED ON THE PREVIOUSLY TIED PROFILE BRACKETS.

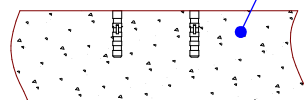
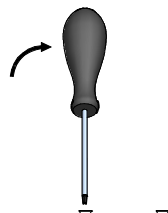
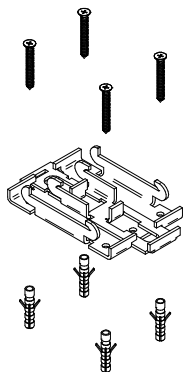
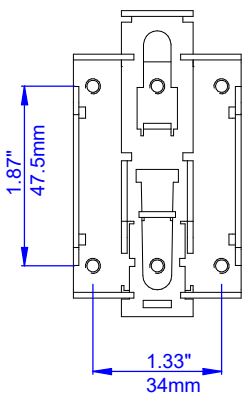

Existing concrete

PAY ATTENTION TO THE POSITION OF THE PROFILE

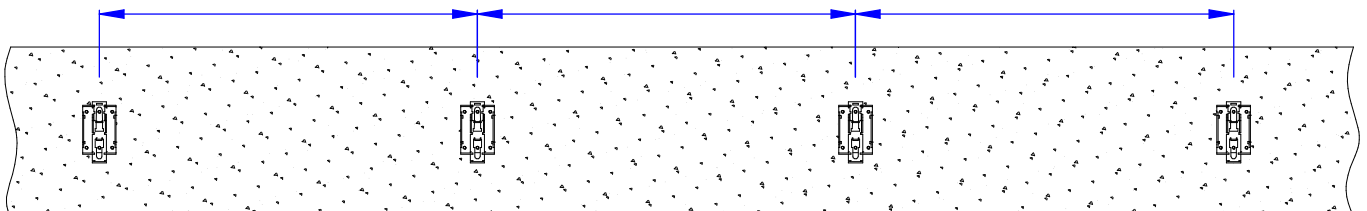
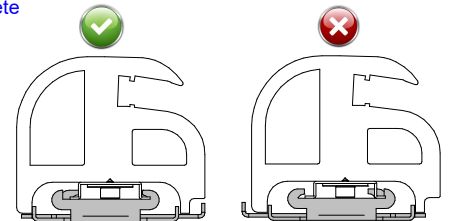

2.b SOFT GROUND INSTALLATION:
FIX THE SPIKES TO THE BRACKETS.
DROP THE PROFILE WITH THE
SPIKES ATTACHED TO THE GROUND

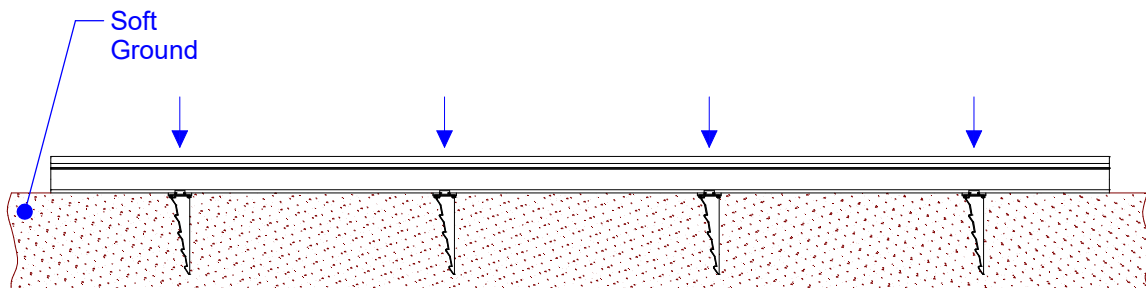
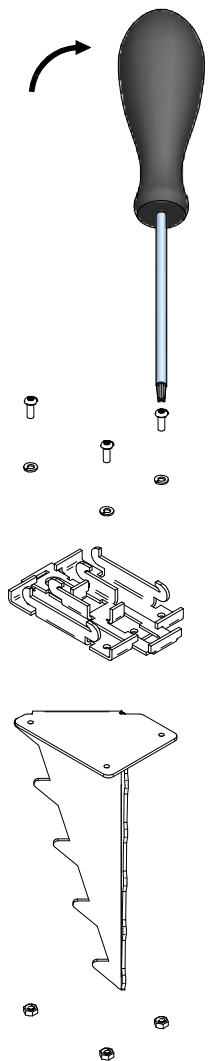

3 PLACE THE PROFILE OVER THE QUICK RELEASE BRACKETS THAT WERE PREVIOUSLY SECURED TO THE GROUND. PUSH THE RELEASE BUTTON OF THE BRACKET TO ALIGN IT WITH THE METAL PLATE INSTALLED ON THE UNDERSIDE OF THE PROFILE, AND RELEASE IT.

4 ONCE IT CLICKS, THE PROFILE WILL BE SECURELY ATTACHED TO THE QUICK RELEASE BRACKET.

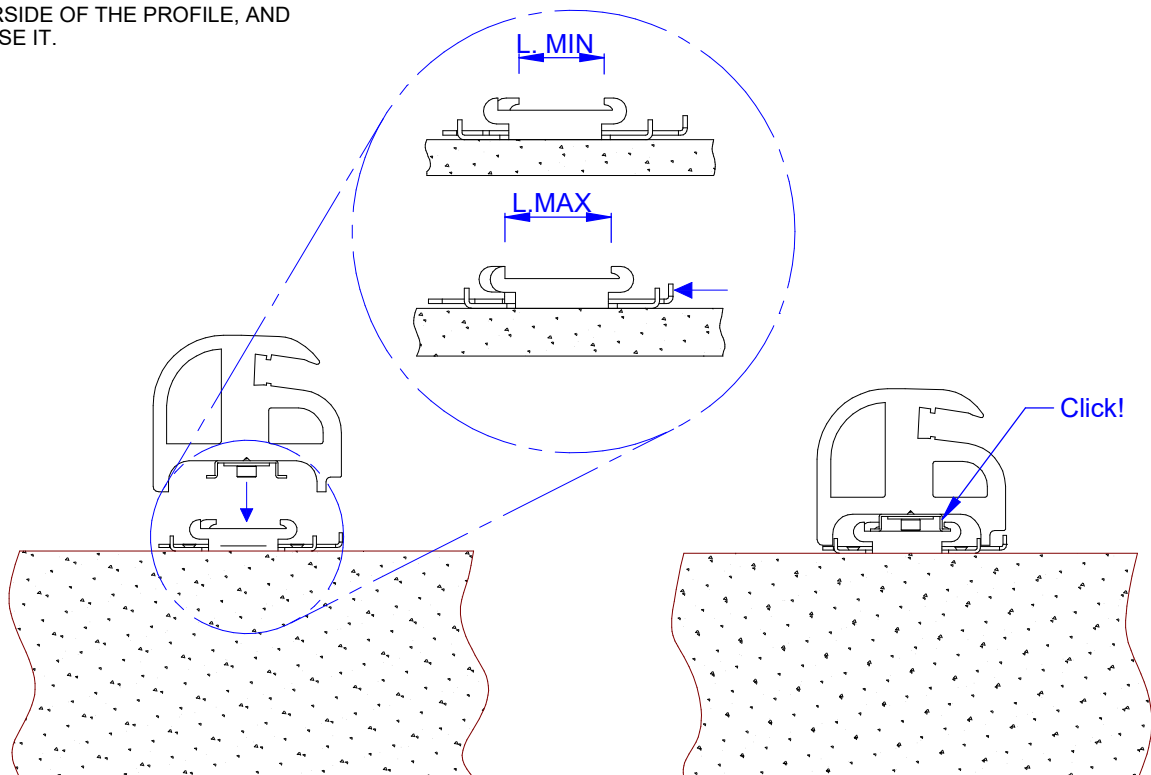

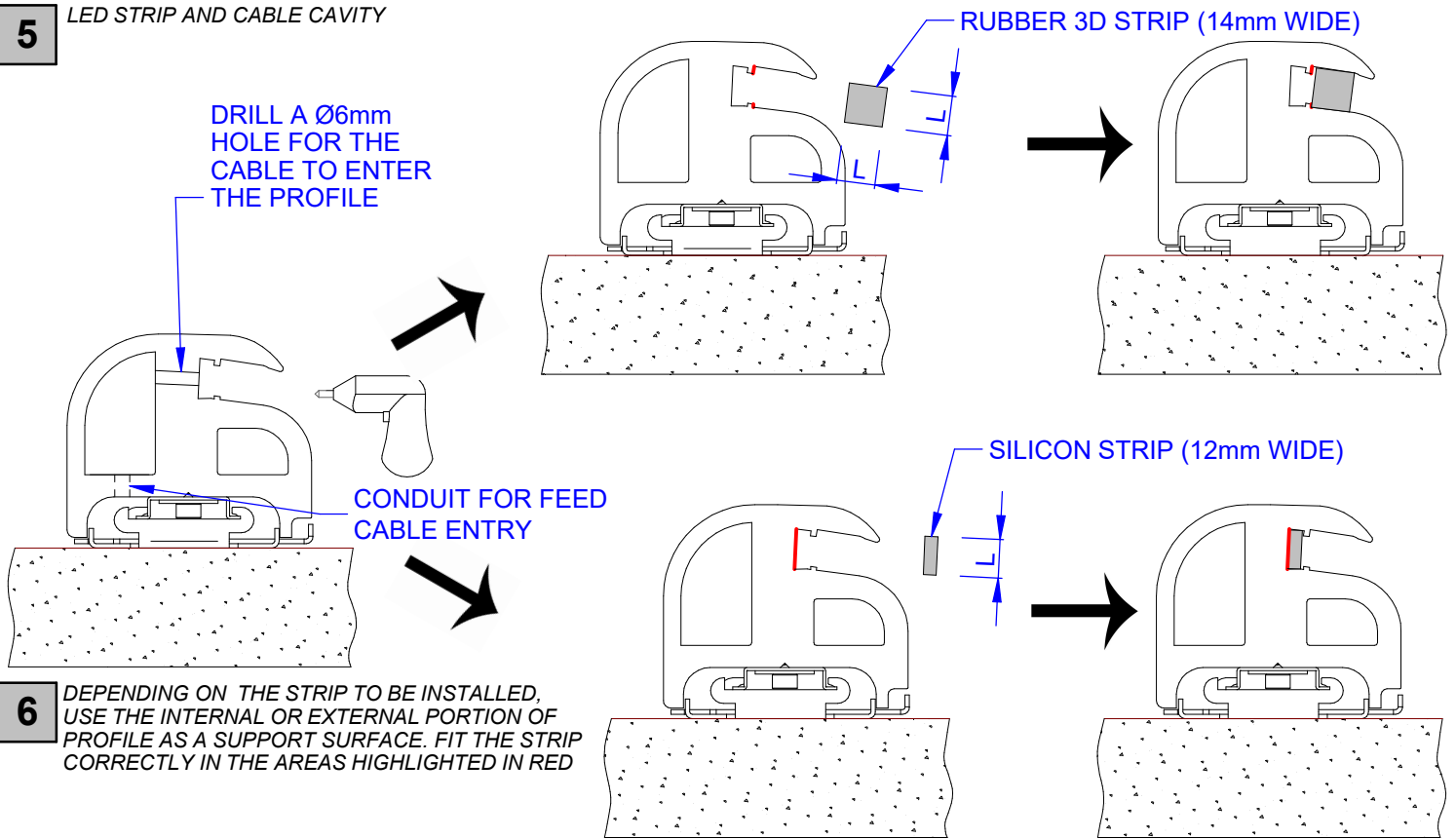
5**LED STRIP AND CABLE CAVITY****7.a**

CONNECT LED STRIP TO THE WIRES COMING FROM THE REMOTE DRIVER, USING 3M SCOTCHLOK™ 314 INSULATION DISPLACEMENT CONNECTORS (NOT INCLUDED)

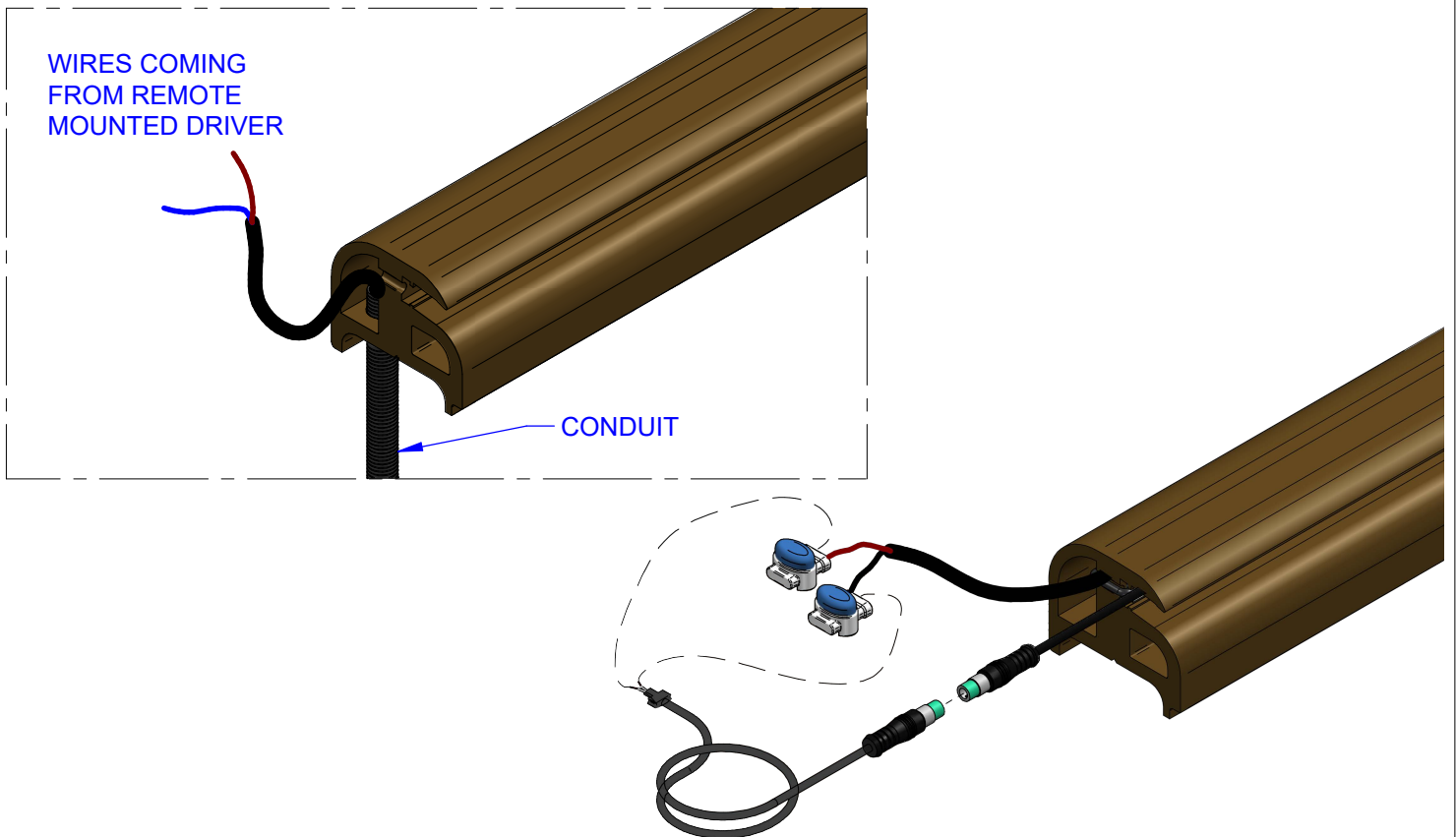

RUBBER STRIPS (SHOWN ABOVE) HAVE CONNECTORS AND REQUIRE A SEPARATE POWER FEED CABLE. DO NOT CUT THE CONNECTOR OF THE RUBBER STRIP.

SILICONE STRIPS DO NOT HAVE CONNECTORS, AND THE SPLICE CAN BE DONE DIRECTLY FROM THE STRIP TO THE WIRES COMING FROM THE REMOTE MOUNTED DRIVER

7.b PUSH THE STRIP INTO THE PROFILE IN A WAY THAT
ALLOWS THE END CAPS TO BE INSTALLED

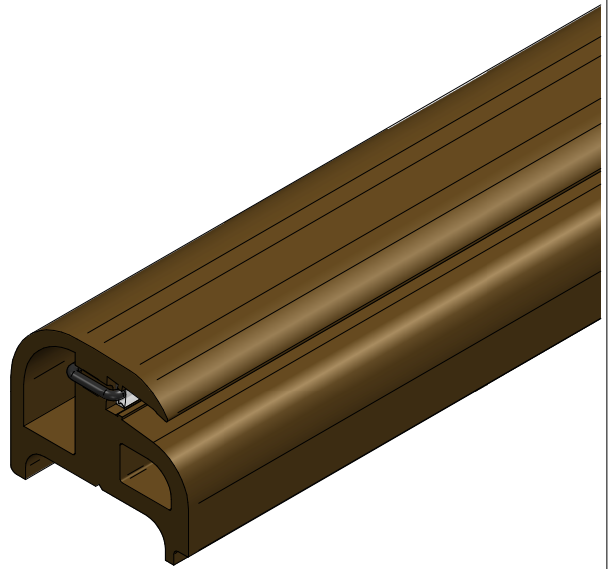

THE CABLE MUST NOT PROTRUDE FROM THE PROFILE

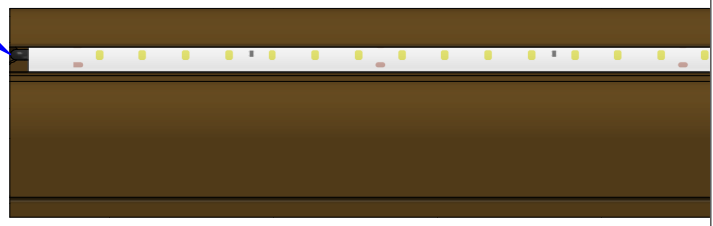

8 MINIMUM BENDING RADIUS 35.4" (900mm)

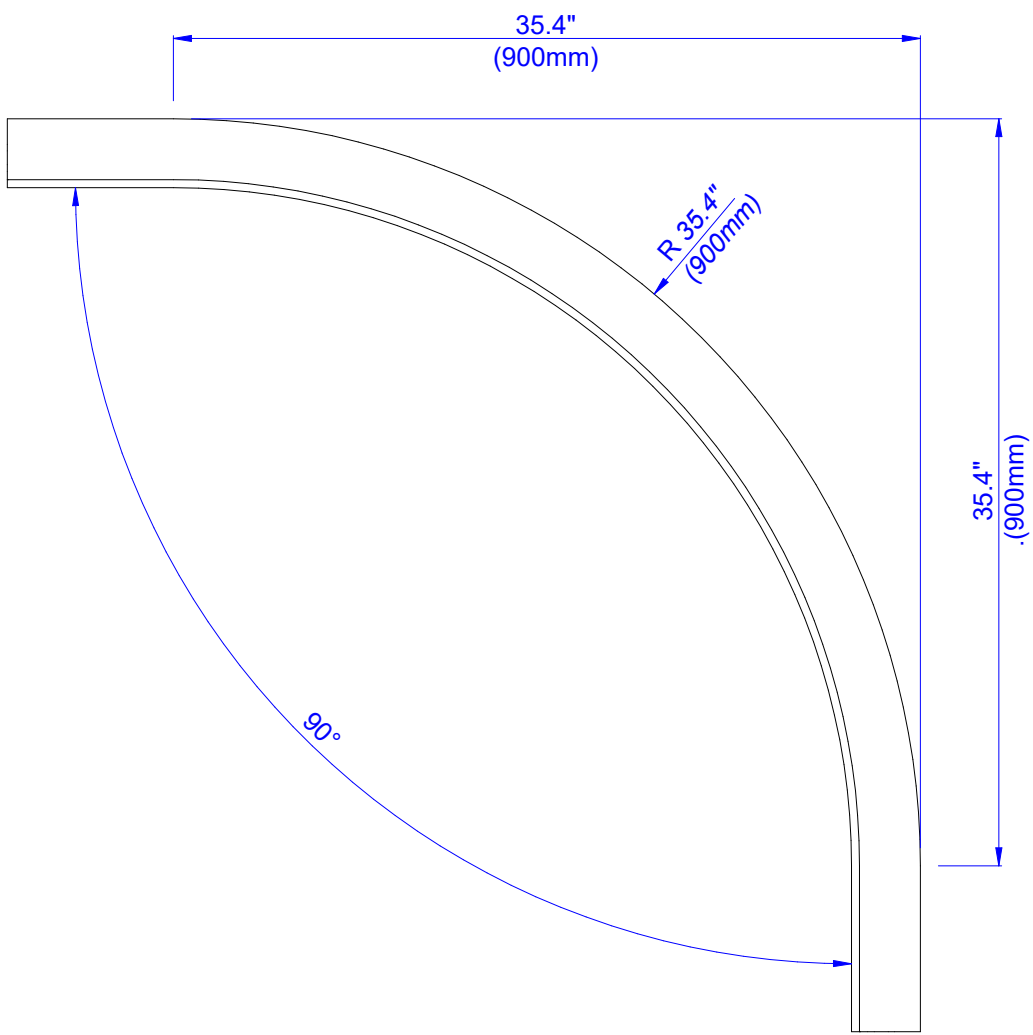

9

USE STRAIGHT OR CORNER JOINERS TO CONNECT MODULES. TO INCREASE THE CONNECTION STRENGTH, SLIGHTLY OPEN THE FLAP ON THE JOINERS. INSERT THE JOINER IN THE PROFILES.

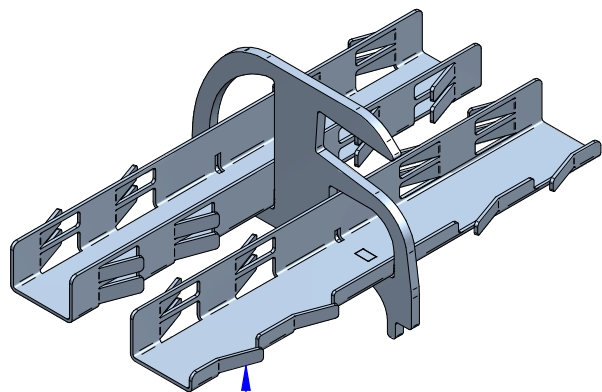

SLIGHTLY OPEN FLAPS BEFORE INSERTING INTO THE PROFILES

STRAIGHT JOINER

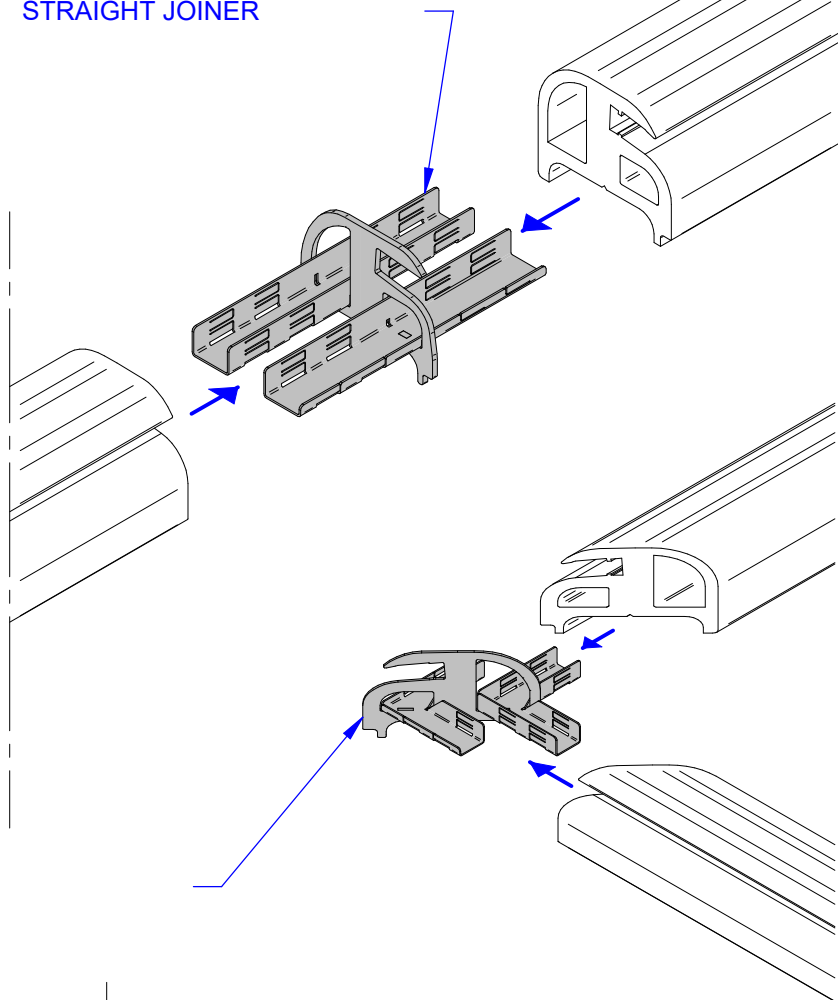

90° OUTSIDE CORNER JOINER

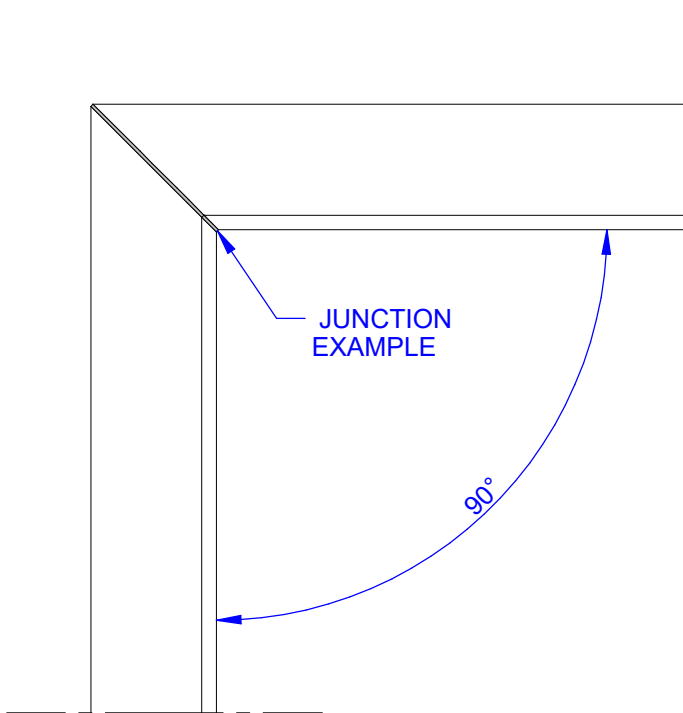

90° INSIDE CORNER JOINER

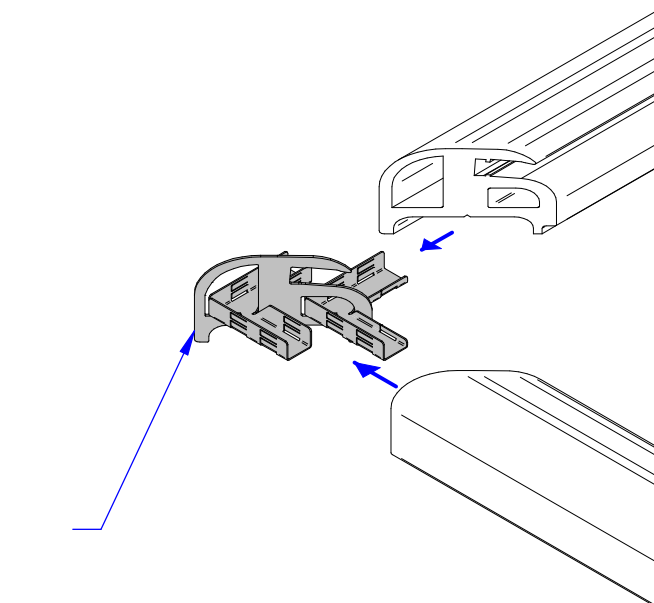

10

INSERT THE END CAPS AT THE ENDS OF THE PROFILE. TO INCREASE THE CONNECTION STRENGTH, SLIGHTLY OPEN THE FLAP ON THE END CAPS. INSERT THE JOINER IN THE PROFILES.

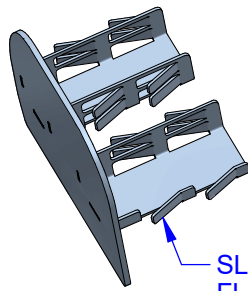

SLIGHTLY OPEN FLAPS BEFORE INSERTING INTO THE PROFILES

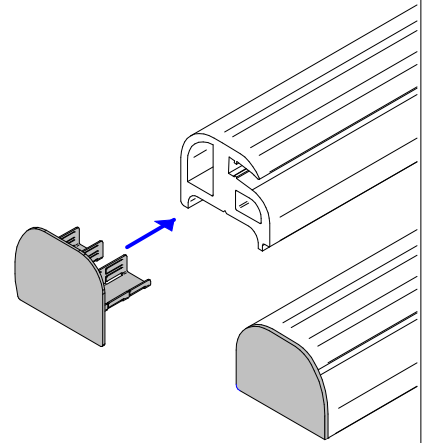

RIGHT END CAP

LEFT END CAP

STRAIGHT JOINER

