

STILNOVO



inter-lux.com/stilnovo



STILNOVO

Post-World War II Italy established itself internationally thanks to the happy combination of industrial design and the most famous names in architecture. Stilnovo was one of the first companies to transfer this combination to the lighting sector: since its foundation in 1946, it has never ceased to fascinate historians, collectors and design lovers.

Today, after the acquisition by Linea Light Group, Stilnovo aims to become a world leader for the home, hotel and restaurant, thanks to a legacy of light and contemporary lamps, presented in this catalog together with some re-editions of magnificent icons of the past, designed by the Masters of 20th century design.

Table



Buonanotte 5

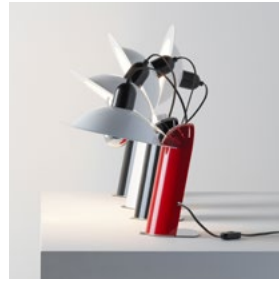

Lampiatta 10



Megafono 16



Minibox 22



Minitopo 29



Topo 35



Valigia 42

Floor



Topo 33



Triedro 39



Galassia 48

Suspension



Megafono

18



Galassia

46

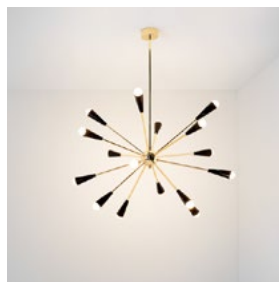

Sputnik

50

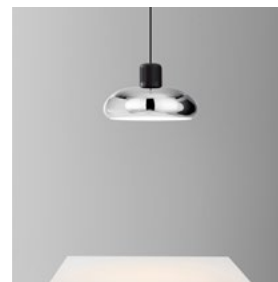

Trepù

53

Wall/ ceiling



Lampiatta

13

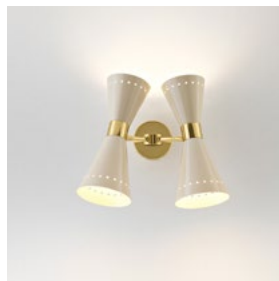

Megafono

20

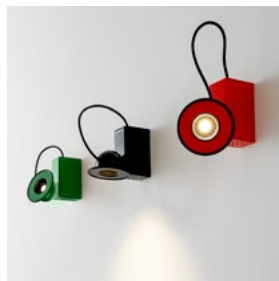

Minibox

25



Triedro

37

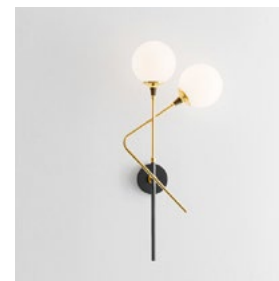

Galassia

49

Buonanotte

1965

Giovanni Luigi Gorgoni



Buonanotte



Buonanotte is a fun lamp that can be adjusted by rotating two metal shades which, moved freely around the spherical diffuser, control the light beam. With a simple gesture, the atmosphere changes: open for good reading or closed and subdued, for pleasant dreams.

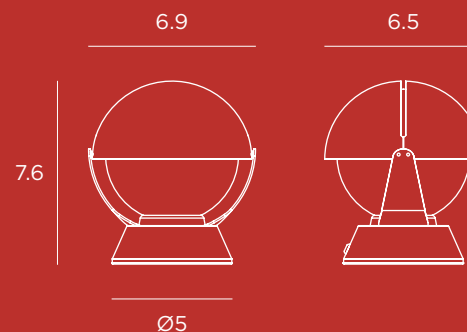

1xE12 5W S14 2700K LED

White 8961
Red 8962
Yellow 8963
Blue 8964

Buonanotte

Metal body painted in white, yellow, red, blue finishes. Duplex glass diffuser included.



Buonanotte



STILNOVO



Buonanotte

designed by
Giovanni Luigi Gorgoni
Milan, 1937

Pupil of Giò Ponti, Ernesto Nathan Rogers, and Vittorio Gregotti. His name is associated with countless prestigious projects created for Milan, Rome, Madonna di Campiglio, Porto Cervo, Benhazi, Misurata, Tripoli, Gedda, Paris, Cannes, Lyon, Yaoundé, London, and New York. In 2007, he was awarded the VIA prize by the French Industry and Design Association.

© Giovanni Luigi Gorgoni

Lampiatta table

1971

Jonathan De Pas
Donato D'Urbino
Paolo Lomazzi



STILNOVO

Lampiatta table



Lampiatta can be easily repositioned without the use of joints or mechanisms: the lampshade is designed to be inserted as desired in one of the four slots of the base, allowing the light to be inclined and directed.

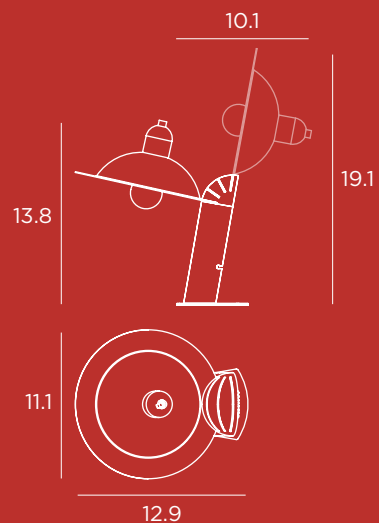

1xE26 7W, A19, 2700K, LED Silver Bowl

White 8971
Black 8972
Red 8973

Lampiatta table

**Body in glossy white, black, red polycarbonate.
Parabola in white painted aluminum. Base in
metal and removable (for wall installation).
Parabola in white painted aluminum.
Removing the steel base from the body,
Lampiatta can be wall mounted.**

STILNOVO



Lampiatta from table to wall

1971

Jonathan De Pas
Donato D'Urbino
Paolo Lomazzi



Lampiatta from table to wall



Removing the steel base from the body, the table lamp Lampiatta can be transformed into a wall light.

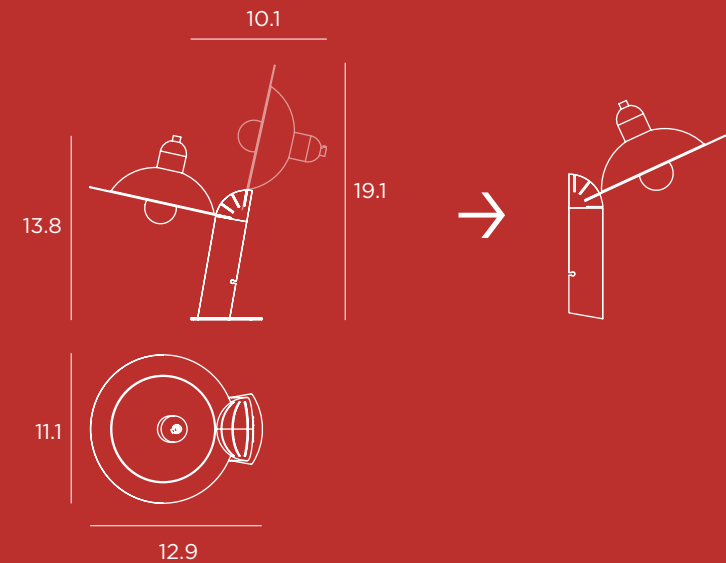

1xE26 7W, A19, 2700K, LED Silver Bowl

White 8971
Black 8972
Red 8973

Lampiatta

designed by

Studio DDL

De Pas, D'Urbino, Lomazzi

Milan, 1932 – Milan, 1991 / J. De Pas

Milan, 1935 / D. D'Urbino

Milan, 1936 / P. Lomazzi

Since founding “Studio De Pas, D’Urbino, Lomazzi” in 1966, these three designers have made their mark mostly thanks to their non-conventional, pop-inspired style, recognizable in many of their interior design objects. They have collaborated with the most influential companies in the furniture sector and won the prestigious Premio Compasso d’Oro in 1979 with the Sciangai coat rack for Zanotta. Studio DDL production is documented in historical literature on Italian design and in the main international publications on architecture and industrial design. Many of their works are included in the permanent design collections of various museums throughout the world, and have been selected for traveling exhibitions on Italian design.

Their firm continued to work and still works even after the death of De Pas (1932-1991) on the design of architecture, objects, fit-outs, furniture, and in the urban planning sector.



© Studio DDL

Megafono table

1958



Megafono table



Megafono is an iconic 1950s lamp with both direct and indirect light. The double cone directable lampshade, with an ivory or glossy black finish, is combined with the precious brass stem with galvanic gilding, to illuminate with a refined touch.

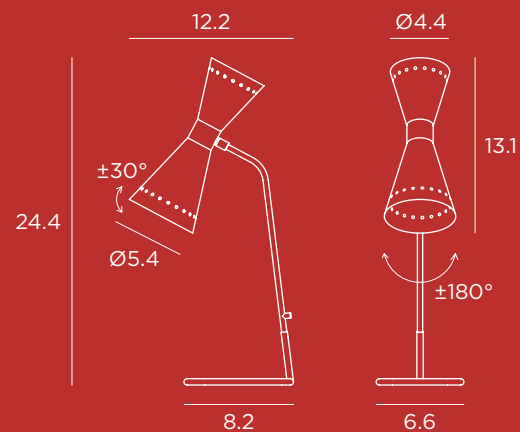

2xE12 S14 2700K 90CRI IF

Black 9574
Ivory 9575

Megafono suspension

1958



Megafono suspension

Megafono is an iconic 1950s lamp with both direct and indirect light. In the suspension version with three, six or eight arms, a prized brass structure bearing galvanic gilding combines with the directable double-cone lampshades in ivory or glossy black, illuminating the environment with elegance.

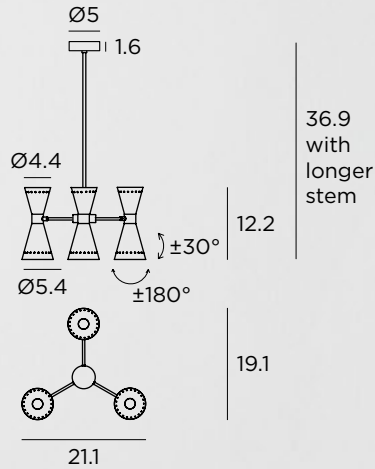

3xE14, S14, 6W, 3000K
90CRI LED

Black 9576
Ivory 9577

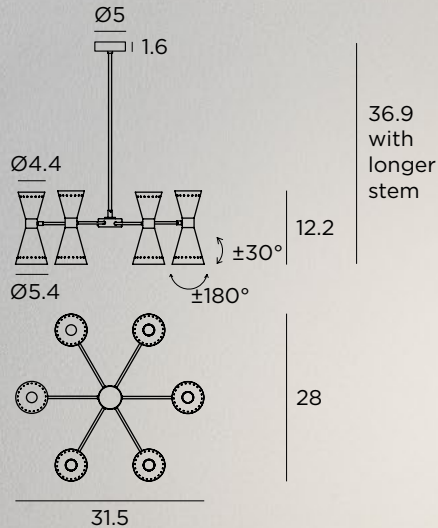

12xE14 S14 3000K
90CRI 6W LED

Black 9568
Ivory 9569

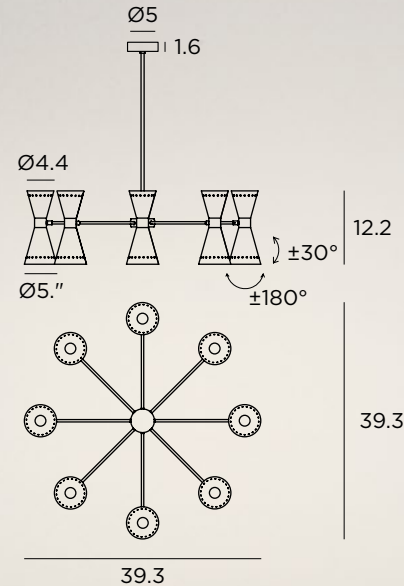

16xE14 6W LED

Black E9566
Ivory E9567

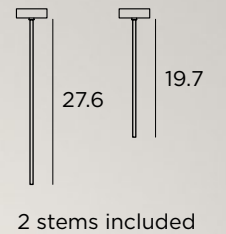

Megafono wall
1958



Megafono wall

Megafono is an iconic 1950s lamp with both direct and indirect light. In the single or double-arm wall lamp version, a prized brass structure bearing galvanic gilding combines with conical lampshades in ivory or glossy black finish, illuminating the environment with elegance.

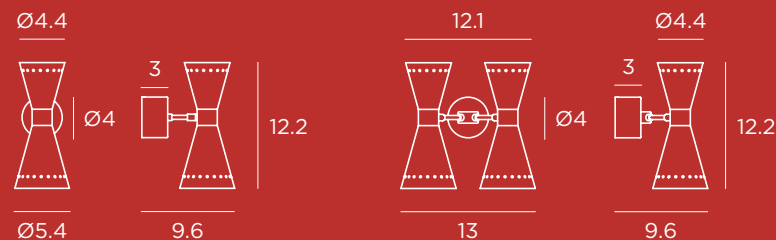

2xE14 S14 3000K 90CRI
6W LED

Black 9570
Ivory 9571

E14 S14 3000K 90CRI
6W LED

Black 9572
Ivory 9573

Minibox table-top

1981

Gae Aulenti
Piero Castiglioni

Available Fall 2022



Minibox table-top



The table-top Minibox is comprised of a metal body, a comfortable handle and an irreverent luminous eye, which recalls the aesthetics of a miners' lamp. The magnetic attachment of the head allows the light to be directed, rendering it suitable for any location, even the most unexpected.

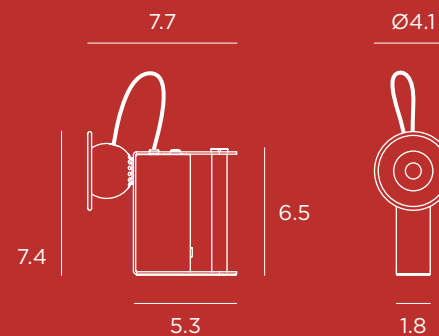

Magnetic head-body connection

1 x powerLED 8.5W

White 9285
Black 9286
Coffee 9287
Green 9588
Red 9589

Minibox table-top

The wall-mounted Minibox consists of metal body painted in glossy white, black, coffee, green or red finishes. Directable head in metal with magnetic coupling, topLED light source.



Minibox wall

1981

Gae Aulenti
Piero Castiglioni

Available Fall 2022



Minibox wall



The wall-mounted Minibox consists of a metal body and an irreverent luminous eye. The magnetic attachment of the head allows the light to be directed, rendering it suitable for any position.

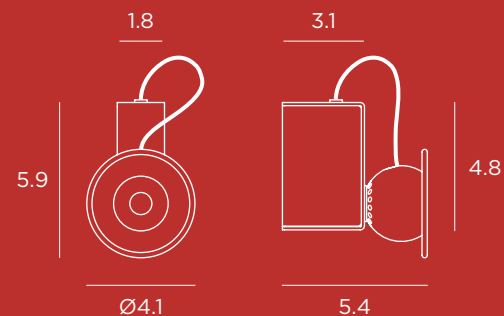

Magnetic head-body connection

1 x powerLED 8.5W

White 9290
Black 9291
Coffee 9293
Green 9293
Red 9294

Minibox wall

The metal body painted in glossy white, black, coffee, green or red finishes. Directable head in metal with magnetic coupling, dimmable topLED light source.



Minibox designed by



© Gae Aulenti Archive

Gae Aulenti

Gaetana Aulenti, born in Northern Italy in 1927, and moved to Milan at an early age to study Architecture at the renowned Milan Polytechnic University, where she defied tradition by being the only one of two women who graduated in her class.

As many of her peers, she started her career in the editorial world by working with the design magazine *Casabella*, immersed in the flourishing Milanese culture and in the Neoliberty movement, distancing herself from the Rationalism tendency of the war period.

Piero Castiglioni

Piero Castiglioni (b. 1944) is an Italian architect specialized in lighting design. Together with his father Livio, Piero Castiglioni developed lighting engineering projects for many public and private surroundings, and in the 1980s, he collaborated with the Italian architect Gae Aulenti. Some of his most significant lighting projects include the Pompidou Centre and the Orsay Museum in Paris.

STILNOVO

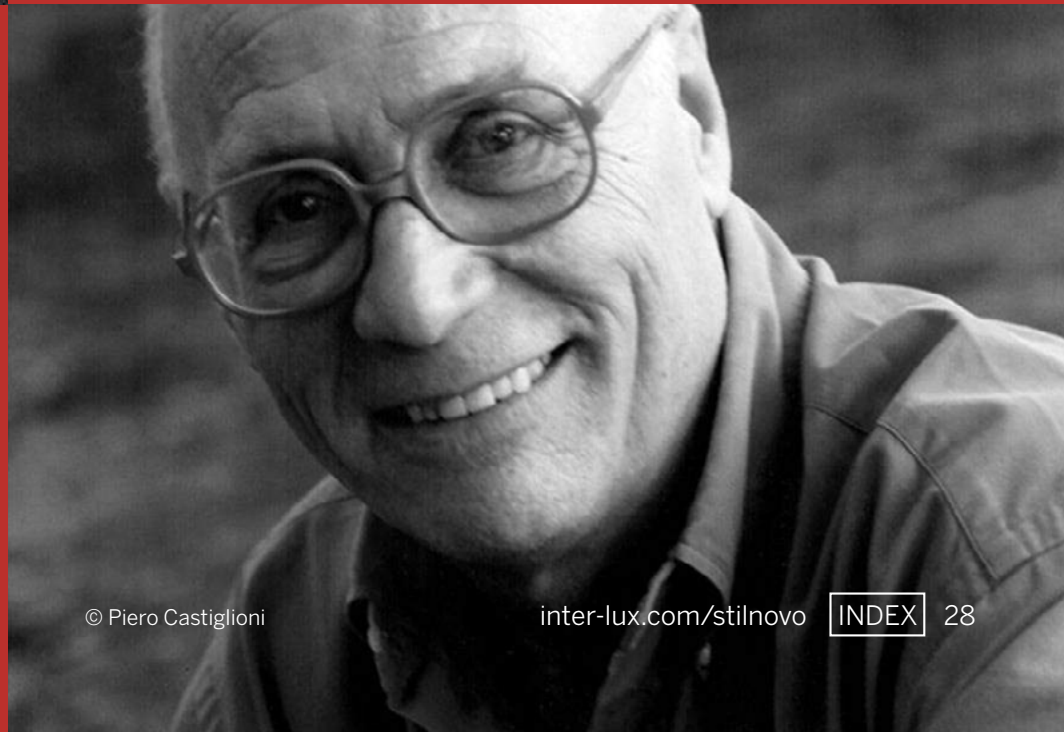

© Piero Castiglioni

inter-lux.com/stilnovo

INDEX

28

Minitopo

1970

Joe Colombo



Minitopo



Minitopo is a charming thing of automotive inspiration: the slits on the shell recall the air intakes of 1960s sports cars, while the shape of the lampshade matches to the envelope of the classic E27 bulb placed inside, like a hood on the engine below. The resulting shape is a reminiscent of a mouse, hence the ironic name. The light is freely directed by the black handle, the tail, placed on the reflector.

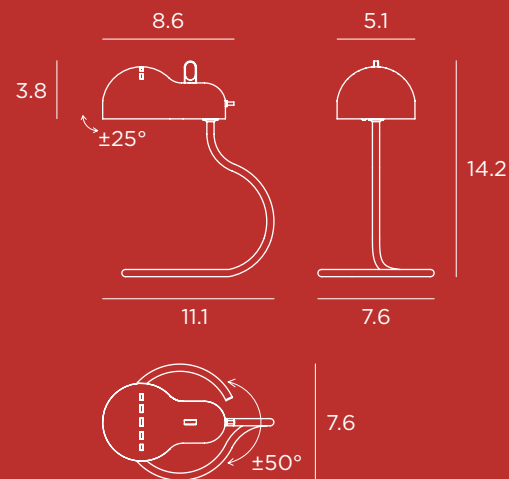

1XE27 7W LED

Red / Red 9064

White 9065

Black 9066

Red / Chrome 9067

Green 9068

Chrome 9068

Gold 9070

Minitopo

Adjustable metal head painted in glossy white, black, red, green, chrome finishes with supporting stem in chromed metal. Special editions: Chrome Special (total chrome), Gold Special (head in galvanic gold and matte black stem), Iconic Red (total Iconic Red). Head interior painted white. Grip in black thermal insulating material.



Minitopo



STILNOVO



inter-lux.com/stilnovo

INDEX 32

Topo floor

1970

Joe Colombo

Available Fall 2022



STILNOVO

Topo floor

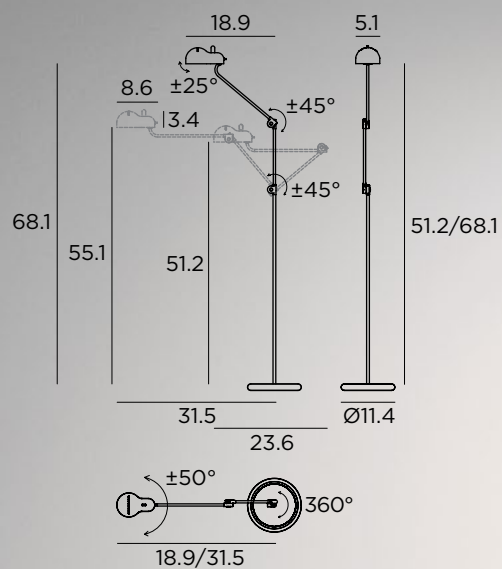

1XE27 7W LED

- White 9081
- Black 9082
- Red 9083
- Green 9084
- Chrome 9085

STILNOVO



Topo table

1970

Joe Colombo



STILNOVO

Topo table



STILNOVO

Topo is a fascinating object of automotive inspiration: the slits on the metal shell are reminiscent of the vents on a 1960s sports car, whilst the lampshade's form corresponds to the casing of the classic E27 bulb it contains, like the bodywork encasing an engine.

The jointed metal arms allow the lamp to be extend or retracted at will.

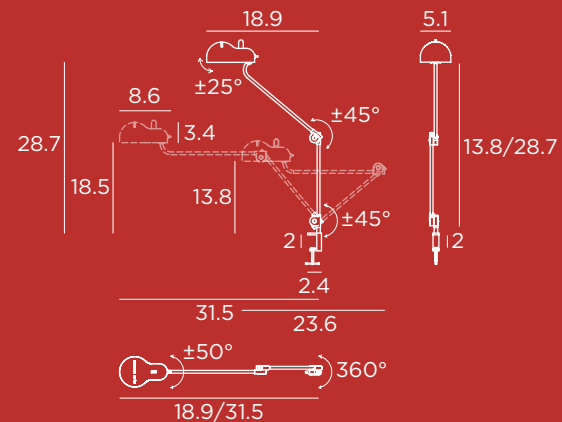

1XE27 7W LED

- White 9071
- Black 9072
- Red 9073
- Green 9074
- Chrome 9075

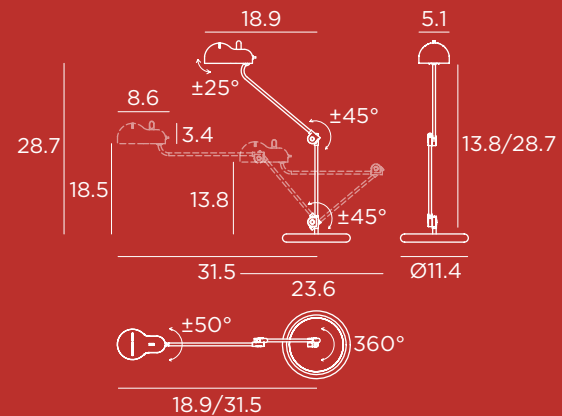

1XE27 7W LED

- White 9076
- Black 9077
- Red 9078
- Green 9079
- Chrome 9080

Triedro wall

1970

Joe Colombo



STILNOVO

Triedro is reminiscent of lighting from a photo shoot. Housing a silver-domed LED bulb, the lampshade is comprised of three contoured and bent metal parts in order to reflect the light downward, without creating glare. The vast flexibility in positioning is guaranteed by the supporting double joint for rotation and inclination of the light source into any position. In the clamp version, it secures easily to suit any needs.

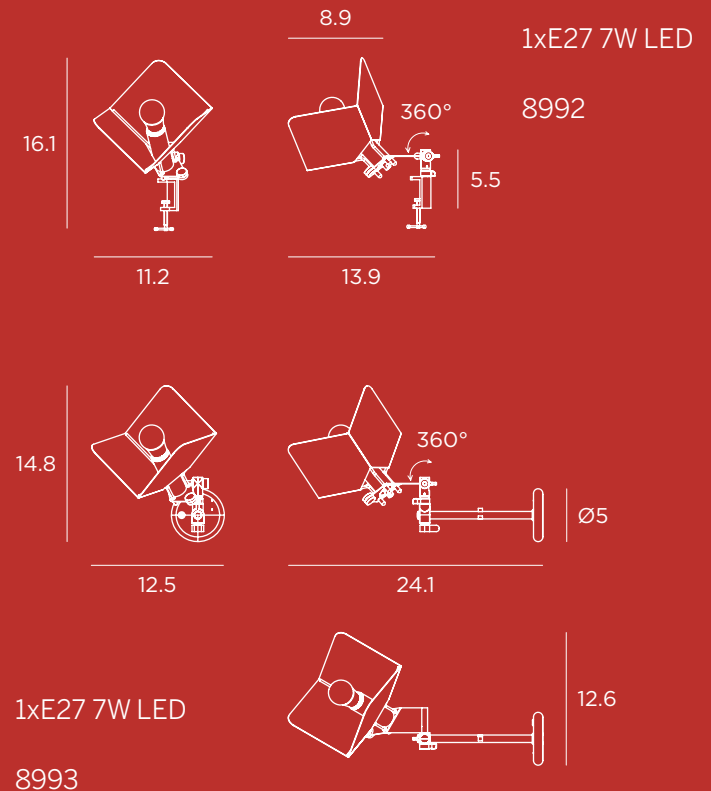

Triedro wall



Triedro floor

1970

Joe Colombo



Triedro floor



The Triedro floor lamp is reminiscent of lighting from a photo shoot. Thanks to the contoured and bent metal lampshade, comprised of three parts, the light from the silver-domed LED bulb reflects without glare. A vast flexibility of movement is guaranteed by the supporting double joint, which allows the light source to rotate, incline and slide along the steel stem secured to the solid, circular base.

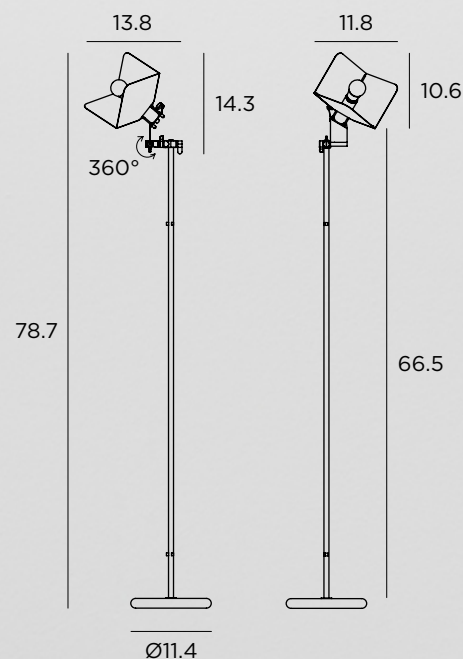

STILNOVO

1xE27 7W LED

8994

Minitopo Topo Triedro

designed by
Joe Colombo

Milan, 1930 – Milan, 1971

Joe Colombo, a pseudonym of Cesare Colombo, is an extremely original Milanese sculptor, painter, architect, and designer. His style, defined as “futuristic”, determined by original figures inspired by the most disparate sources, dynamic furniture systems, and the use of flamboyant metals and colors, contributed to changing the day-to-day life, habits, and customs of Italians and people throughout the world.

To this day, almost fifty years after his death, his most iconic products never cease to amaze.

Twice winner of the Premio Compasso d’Oro (1967 – Spider lamp, 1970 – Candy air conditioner), of the Gold Medal at the Milan Triennale in 1964, and of First Prize at the SMAU in Milan in 1971.

© Ignazia Favata / Studio Joe Colombo

Valigia

1977

Ettore Sottsass Jr



STILNOVO

Valigia



Valigia is ironic and informal: the small handle and the two bearing arches in red piping are connected to the metal vault which contains the light. Valigia is a small architecture without precise confines, clearly conceived to be taken anywhere.

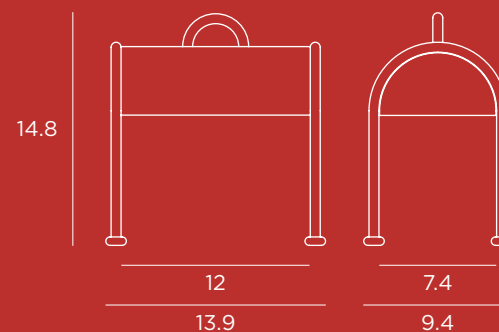

7W E27 G120 2700K

8960

STILNOVO

Valigia

Lampshade in glossy white painted metal.
Lamp body, joints and bulb holder in black
painted metal. Rod in chromed metal, base in
iron with external finishing in polyethylene.



Valigia

designed by
Ettore Sottsass Jr
Innsbruck, 1917 – Milan, 2007

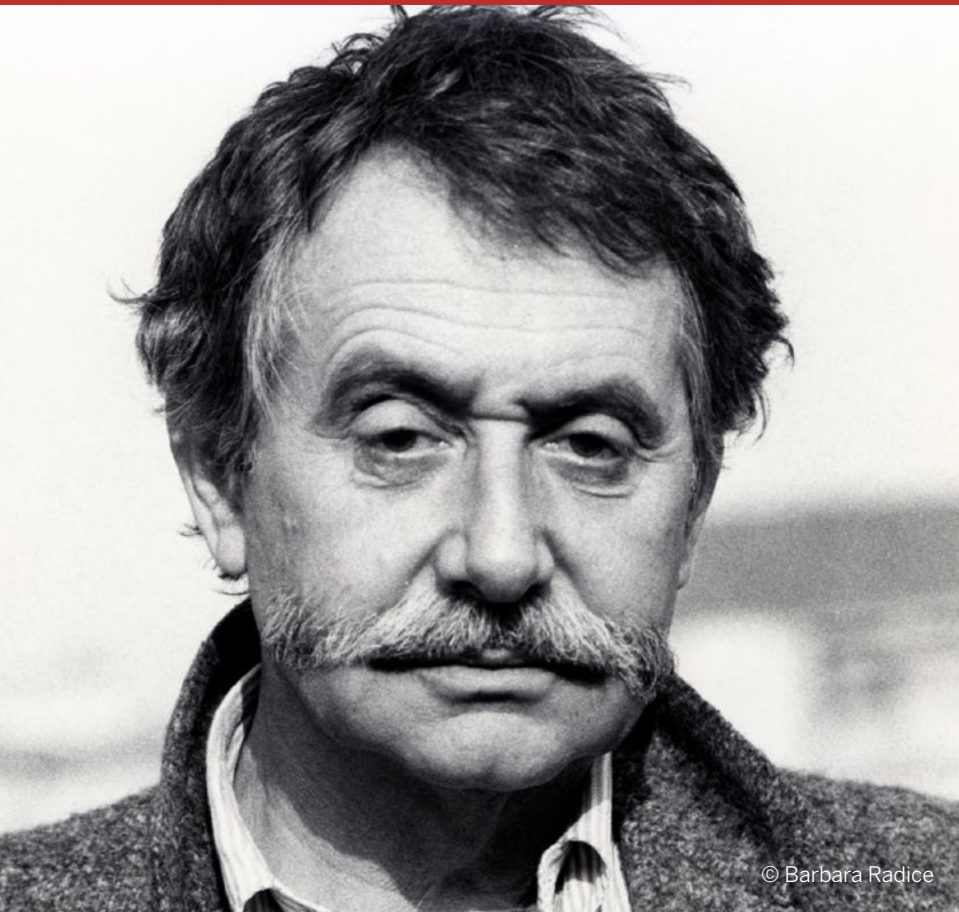

Architect, designer, and photographer, founder of the Memphis Group (an Italian design and architecture collective active between 1981 and 1987), Sottsass, through his production of design objects, always manages to express the emerging ideas of Contro Design or Radical Design, that is, social criticism expressed through objects characterized by the strong experimentalism of materials, technique, and forms, in direct opposition to the common style and trends of the current era.

Winner of the Premio Compasso d'Oro in 1959 and 1970 (Olivetti), and in 1989 (Alessi). Many important exhibitions have been dedicated to him: in 1976 at the Cooper Hewitt in New York and at the International Design Zentrum in Berlin, at the Centre Georges Pompidou in Paris in 1994 and in 2003, at the Design Gallery Milano in 1988, 1993 and 1995, at the Suntory Museum in Osaka in 2000, at the Museo d'Arte Decorativa in Cologne in 2004, and at the MART in Rovereto in 2005. His works are preserved in the most prestigious museums throughout the world.

Galassia suspension

1959



STILNOVO

inter-lux.com/stilnovo

INDEX

46

Galassia suspension

The 1950s charm of the Galassia suspension light, available with six or twelve bulbs, remains unchanged thanks to the combination of the brass with galvanic gilding on the structure and the white triplex blown glass spheres. A priceless collection that enriches the space with a sophisticated retro touch.

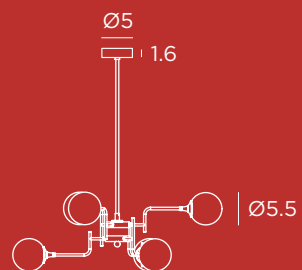

37.8
with
longer
stem

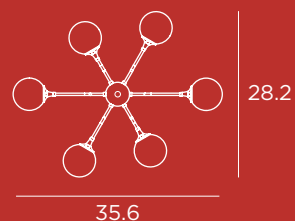

6xE14 6W 3000K LED

9556

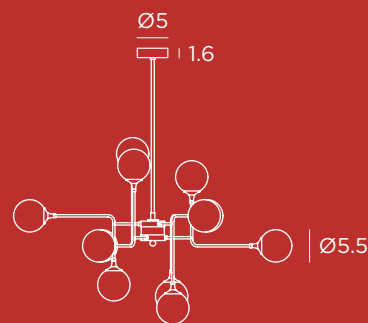

49.3
with
longer
stem

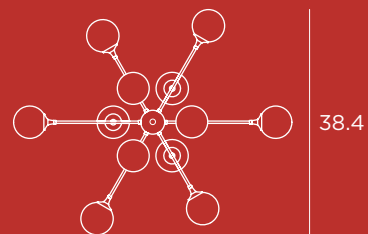

12xE14 6W 3000K LED

9555



Galassia floor

1959



The Galassia floor lamp, with the captivating movement of six white triplex glass light sources, enriches the space with a sophisticated retro touch, preserving its 1950s charm. The base in white Carrara marble embellishes what is a unique lamp. Body in black metal and brass with galvanic gold plating.

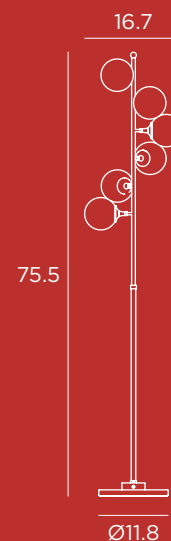

6xE14 6W 3000K LED

9560

STILNOVO

Galassia wall

1959

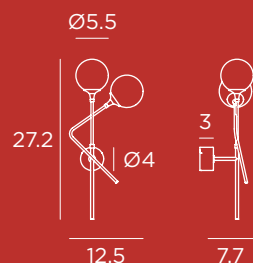
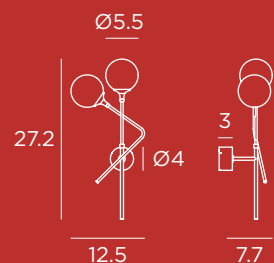

2xE14 6W 3000K LED

Left 9558
Right 9557

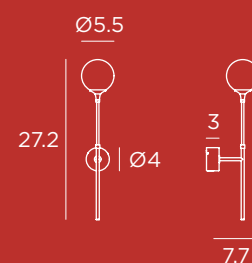

1xE14 6W 3000K LED

9559

Sputnik

1957



Sputnik



Like fireworks, the Sputnik expands in all directions in an explosion of light. The sixteen-arm structure in precious brass with galvanic gilding is elegantly combined with the ends available in black, ivory or in the lively multicolored variant.

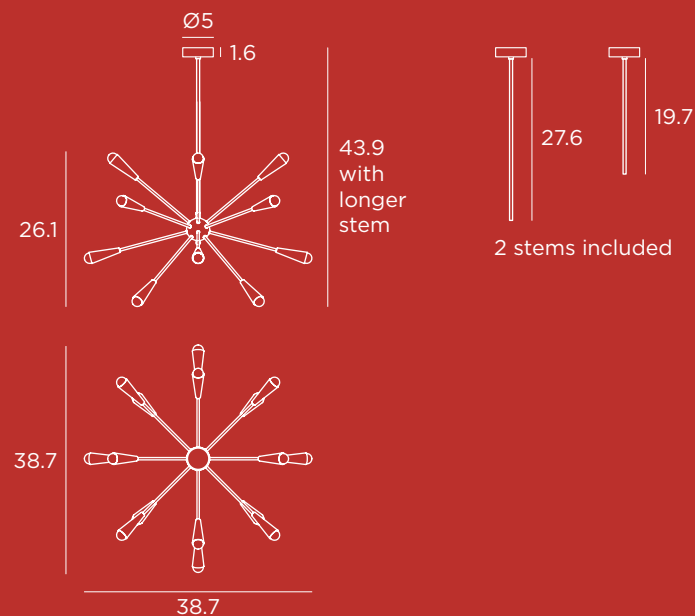

16xE14 6W 3000K LED

Gold/Black E9590

Gold E9591

Gold/Color E9592

Sputnik



STILNOVO



Trepiù

1972

Gae Aulenti
Livio Castiglioni

Available Fall 2022



STILNOVO

inter-lux.com/stilnovo

INDEX

53

Trepiù



Trepiù is an evocative lamp, with an upper shell bearing a marked vintage flavor in two colors and a dome in chromed or glossy white aluminum. Its perfectly-white interior diffuses uniform lighting.

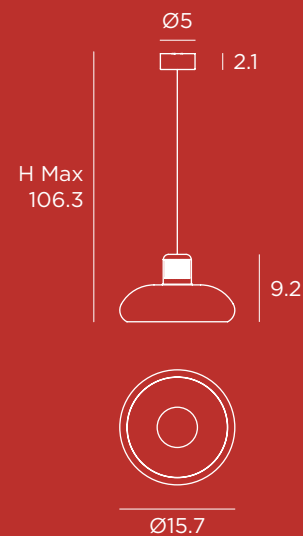

1 x topLED 24W 3000K LED

Black/Chrome 9305
Yellow/Chrome 9306
Black/White 9307
Yellow/White 9308

Trepiù



STILNOVO

Trepiù designed by



© Gae Aulenti Archive

Gae Aulenti

Gaetana Aulenti, born in Northern Italy in 1927, and moved to Milan at an early age to study Architecture at the renowned Milan Polytechnic University, where she defied tradition by being the only one of two women who graduated in her class.

As many of her peers, she started her career in the editorial world by working with the design magazine *Casabella*, immersed in the flourishing Milanese culture and in the Neoliberty movement, distancing herself from the Rationalism tendency of the war period.

Livio Castiglioni

Livio Castiglioni was born in 1911 in Milan, where he graduated in architecture in 1936. He opened a firm with architect Luigi Caccia Dominioni, which his brothers Pier Giacomo and Achille would later join. Lights, sounds, and audiovisuals were his main interests.



© Piero Castiglioni

inter-lux.com/stilnovo

INDEX 56

STILNOVO



inter•lux

inter-lux.com/stilnovo