

## Installation and Maintenance Instructions

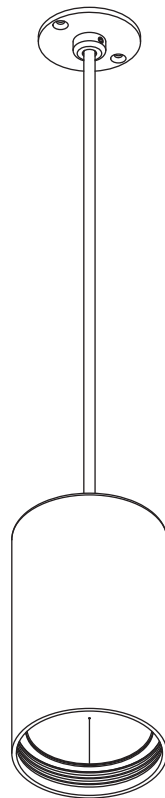

**IMPORTANT: All wiring connections must be made before switching on mains power.**

 Xicato LED Module

 Please retain these instructions for future reference

**IP20** Indoor Use Only

<sup>t</sup><sub>a</sub> 35°C Rated maximum ambient temperature

## Electrical Supply

Installation must be carried out by a qualified electrician in accordance with BS 7671:2008 Wiring Regulations. 230/240V AC 50/60Hz mains supply to a suitable SELV LED Driver.

Site conditions: LED equipment is more susceptible to static damage and over voltage than previous technology. Before handling or connecting to the mains supply ensure that all Stoane Lighting (SL) products are protected from static discharge and that the mains supply is to regulation. (230V +10 -6%)

This fitting is supplied with a Xicato LED module. Refer to the fitting label for the module version and wattage. More information on the module can be found on the attached technical note or at [www.xicato.com/support](http://www.xicato.com/support)

Mains cables must be double insulated, strain relieved and separated from E.L.V output cables.

**This unit requires a constant current driver. Refer to attached technical note for Max current.**

**Observe polarity:  
Positive (+) is marked as RED.  
Incorrect supply or reverse polarity can cause irreparable damage.**

**All connections must be made before switching on mains.** If the supply is energised prior to making the connections to the fitting then the resulting surge will damage the LED.

The entire dimming control circuit source must be of SELV insulation class.

## Maintenance:

All lighting equipment is delicate and easily damaged through misuse or inappropriate installation (mechanical or electrical). Repairs and replacements may cause delays and will be chargeable. Contact SL for support if required.

All Stoane Lighting products are covered by a five year Warranty and a 25 year Duty of Care. Products are designed to be upgraded, adapted and refreshed using our comprehensive ReNew service. For more information on our ReNew service and for full Warranty terms and conditions visit [stoanelighting.com](http://stoanelighting.com) or contact us at the address shown.

The light source contained in this luminaire shall only be replaced by the manufacturer or his service agent or a similar qualified person.

If the external flexible cable or cord of this luminaire is damaged, it shall be exclusively replaced by the manufacturer or his service agent or a similar qualified person in order to avoid a hazard.

Full disassembly notes are available on our website, and are accessed by entering your product serial number into the search function of our website. Serial numbers are typically located in an area that is not visible when the fitting is installed.

## Cleaning:

Fully isolate the fitting and allow to cool.

Clean the fitting with a slightly damp lint free cloth from a mild solution of soap and water. The fitting must be completely dry before reconnecting power.

Incompatible or abrasive chemicals can damage the fitting, contact SL for advice if required.

## Installation

Check that the mounting surface is suitable for the installation of this fitting. **Fitting Weight : 1.1lbs (0.5kg)**

A suitable hole is required for the supply cable.

Step 1 Make mains connections to SELV LED driver and extra low voltage connections to the fitting.

Step 2 Adjust the drop height as required and tighten the grub screw in the side of the mounting plate to hold the cable securely in place.

**Take care not to over tighten the grub screw as it will damage the cable insulation.**

Step 3 Mount the fitting with two suitable fixings.

All suspended installations should be inspected by a competent person at least once a year

**WARNING: Do not look at exposed LED lamps in operation. Eye injury can result.**

Additional items should not be hung or suspended from this fitting. SL takes no responsibility for additional items added by others or the consequences of those items.

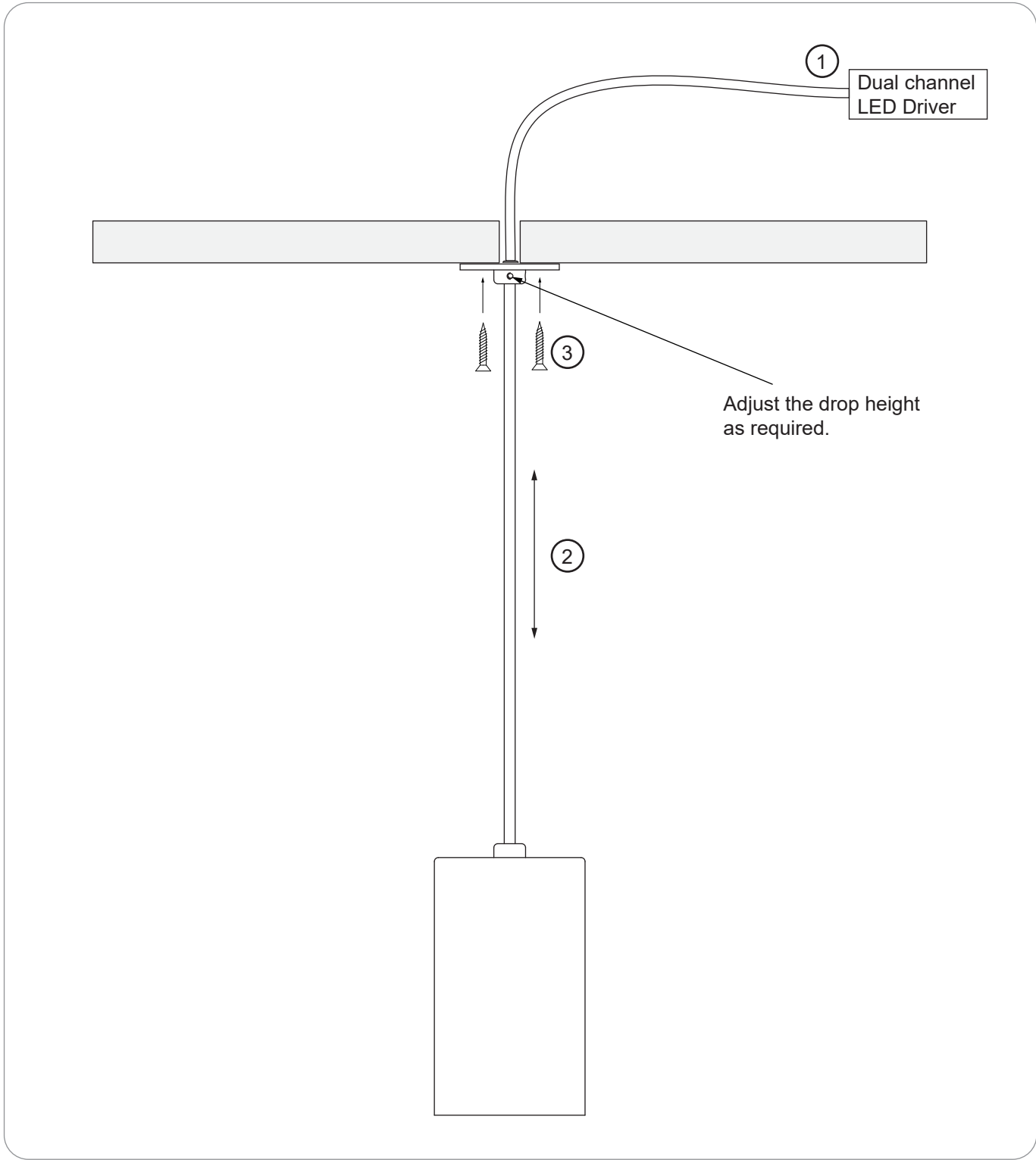

## MODULE AND ACCESSORIES

The colour temperature and lumen output can be found on the product label on the fitting.

To add/remove accessories:

Isolate the fitting from the supply and allow to cool.

Step 1 To remove accessories and access reflector remove the circlip.

Step 2 Replace reflector/accessories as required and replace circlip to secure.

