



WARNING:
INSTALL PRODUCT IN ACCORDANCE WITH LOCAL AND NATIONAL ELECTRICAL CODES; BY A QUALIFIED ELECTRICIAN.



WARNING:
FAILURE TO COMPLY WITH THE INSTALLATION INSTRUCTIONS MAY RESULT IN DEATH OR SERIOUS INJURY.



WARNING:
READ ALL SAFETY INSTRUCTIONS INCLUDED WITH LUMINAIRE BEFORE INSTALLING LUMINAIRE.

CAUTION:

THIS IS AN ELECTRONIC DEVICE. CARE MUST BE TAKEN DURING STORAGE AND HANDLING. STORE IN A CLEAN, COOL AND DRY LOCATION. ELECTROSTATIC DISCHARGE (ESD) CAN HARM THIS PRODUCT. AVOID STATIC DISCHARGE WHILE HANDLING THIS PRODUCT.

CAUTION:

INTER-LUX IS NOT RESPONSIBLE FOR THE STRUCTURAL INTEGRITY OF THE BUILDING TO SUPPORT THE LUMINAIRE. ADDITIONAL BACKING MAY BE REQUIRED.

TRIMETRIC VIEW

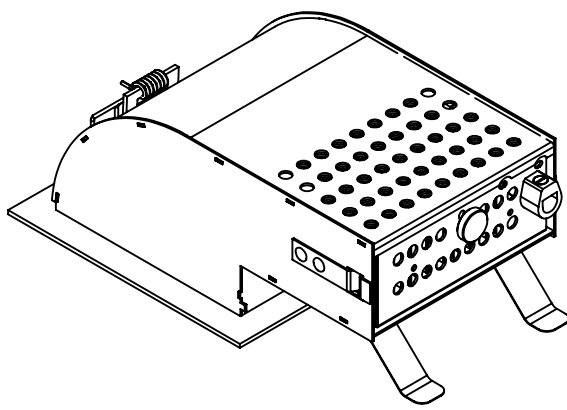

PACKAGE INCLUDES:

(A) Housing

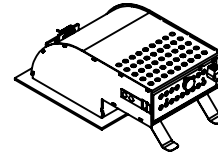

Light Engine Insert (B)

(C) Driver Box



ITEMS NEEDED (SUPPLIED BY OTHERS):

Philips Head #2 Screwdriver



Wire Connectors



Wire Strippers



Ceiling Saw



MOUNTING DIMENSIONS

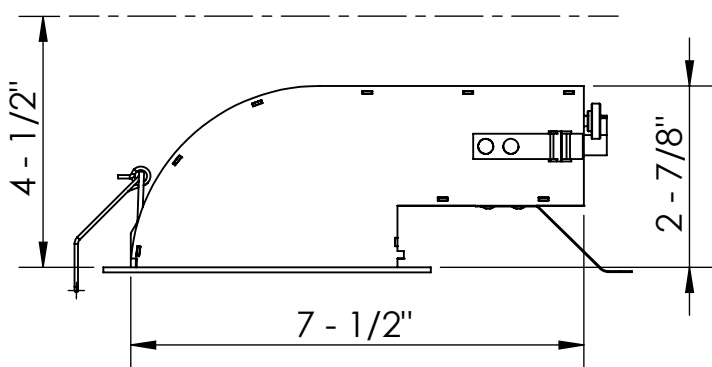

4 - 1/2" Minimum Ceiling Void Depth, 5/8" Max Wall Thickness

SURFACE CEILING WASH

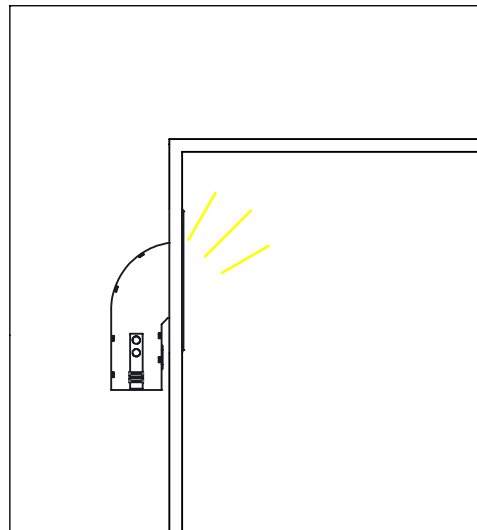

SURFACE FLOOR WASH

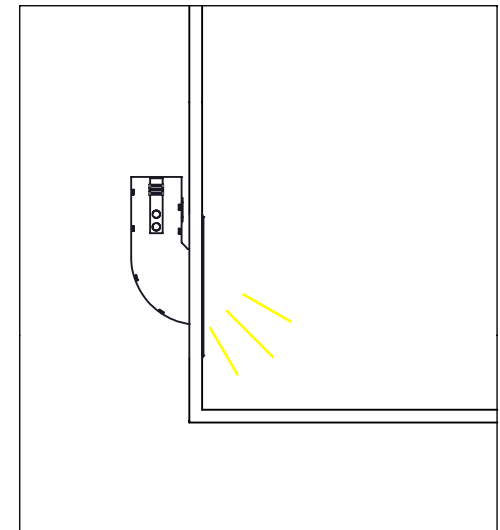

MOUNTING INSTALLATION STEPS



TURN OFF MAIN POWER BEFORE PROCEEDING!

Step 1: Cut Hole in the Wall and ensure minimum void depth is available for installation (5/8" Maximum Wall Thickness). Then install Remote Drivers (C). If Drivers are mounted above ceiling, clear insulation at least 3" around each side of the Drivers.

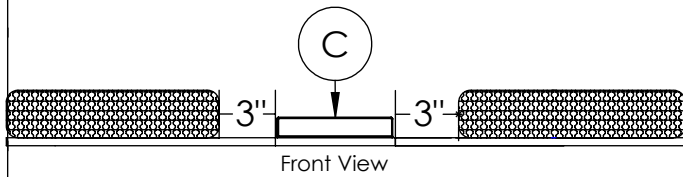
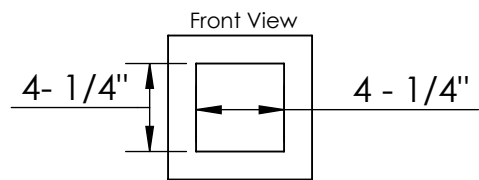

Step 2: Make connections between AC Power/Dimming and Remote Driver (C) in adherence with Local and National Electric Codes.

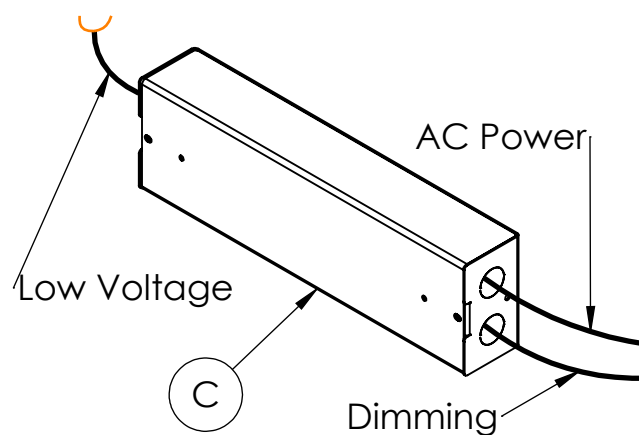

Step 3: Pull Low Voltage leads down and through wall opening. Make the connection between the Driver (C) and the AC/Dimming leads.

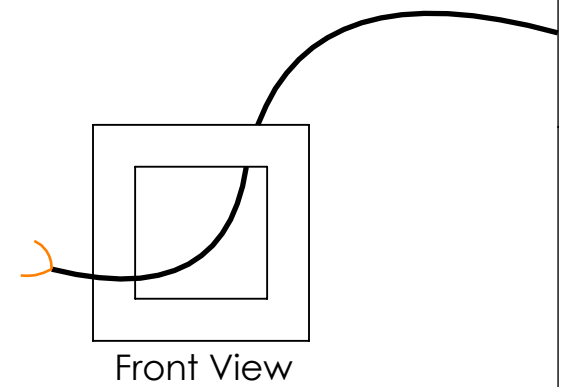

Step 4: Pull Low Voltage leads through Housing (A) and install Housing (A) into wall. Ensure spring clips are engaged.

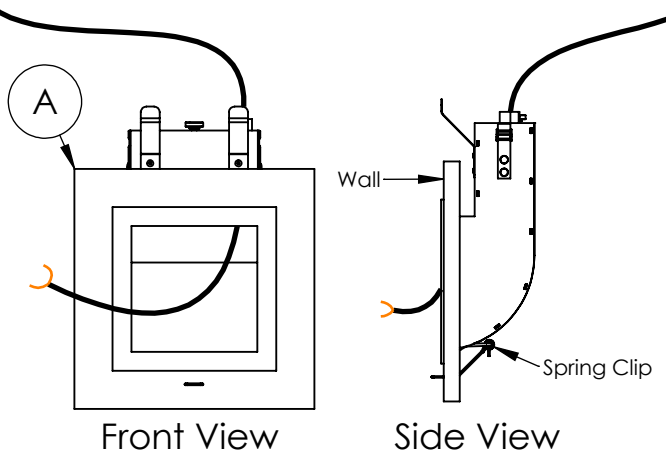

Step 5: Connect the Light Engine Insert (B) to the Low Voltage wires. Then insert Light Engine (B) into Housing (A) as shown below. Ensure that it clicks into place and that small lip is facing towards the wall.

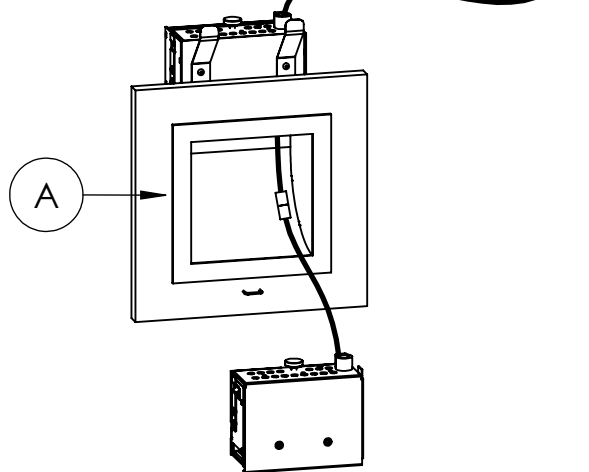

Step 6: Power product and test for proper operation.

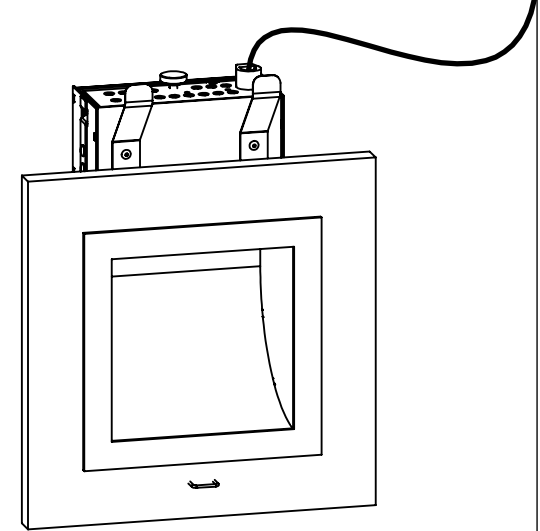



WARNING:
INSTALL PRODUCT IN ACCORDANCE WITH LOCAL AND NATIONAL ELECTRICAL CODES; BY A QUALIFIED ELECTRICIAN.



WARNING:
FAILURE TO COMPLY WITH THE INSTALLATION INSTRUCTIONS MAY RESULT IN DEATH OR SERIOUS INJURY.



WARNING:
READ ALL SAFETY INSTRUCTIONS INCLUDED WITH LUMINAIRE BEFORE INSTALLING LUMINAIRE.

CAUTION:

THIS IS AN ELECTRONIC DEVICE. CARE MUST BE TAKEN DURING STORAGE AND HANDLING. STORE IN A CLEAN, COOL AND DRY LOCATION. ELECTROSTATIC DISCHARGE (ESD) CAN HARM THIS PRODUCT. AVOID STATIC DISCHARGE WHILE HANDLING THIS PRODUCT.

CAUTION:

INTER-LUX IS NOT RESPONSIBLE FOR THE STRUCTURAL INTEGRITY OF THE BUILDING TO SUPPORT THE LUMINAIRE. ADDITIONAL BACKING MAY BE REQUIRED.

Wiring Key

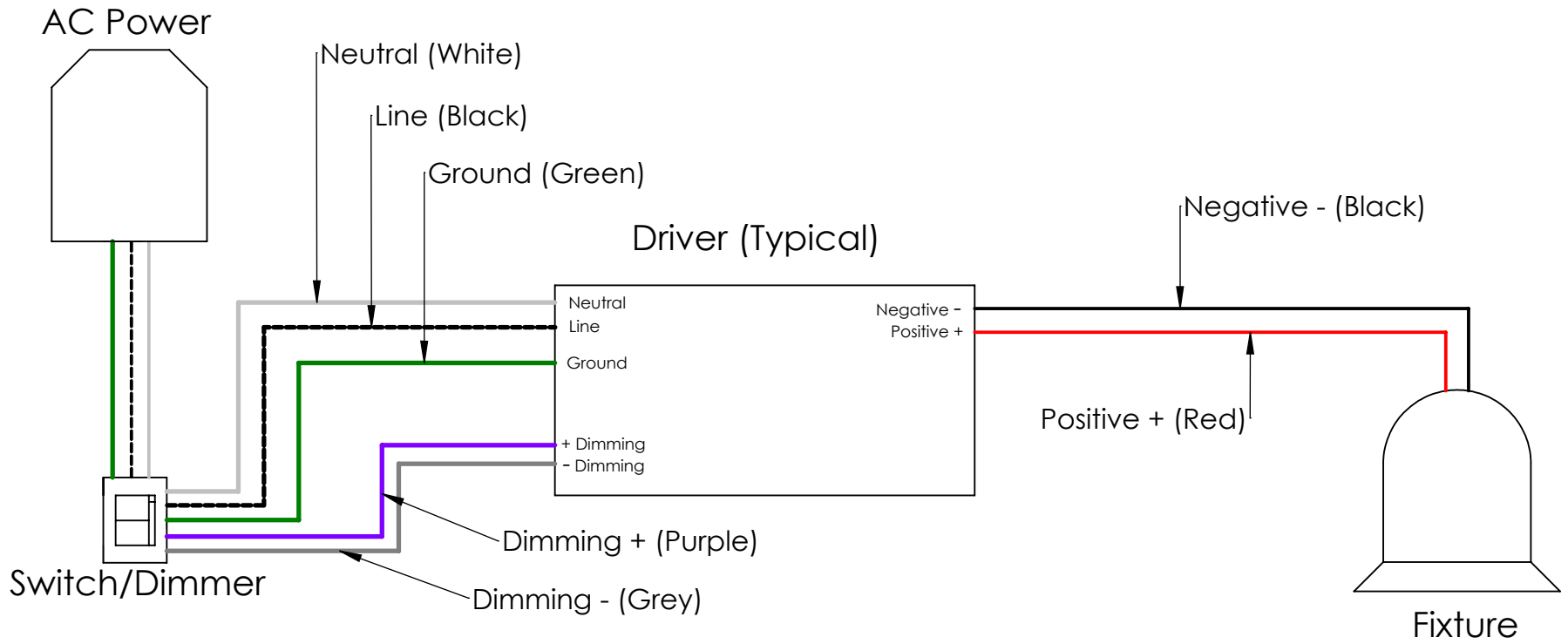

Maximum wire distance and voltage drop to be calculated by installer.

Red	Black	Green	Black	White	Purple	Grey
Positive	Negative	Ground	Line	Neutral	Dimming +	Dimming -

Driver Wiring Diagrams

Standard Non-Dimming SPH (Standard phase dimming wired for forward phase)

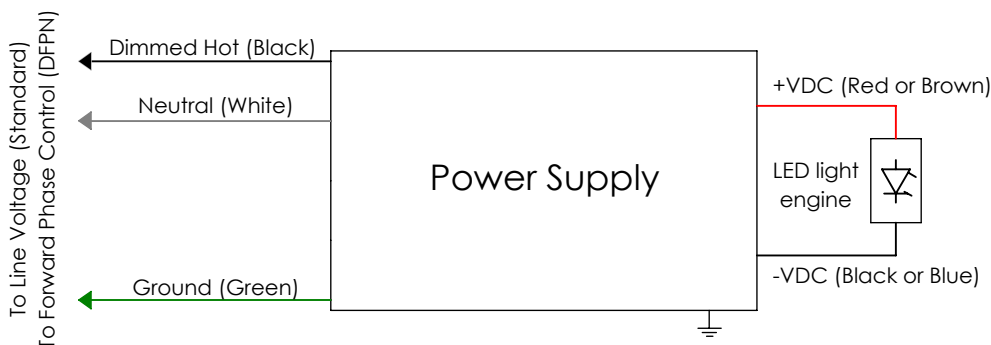

DFPN (Lutron forward phase dimming) SPH (Standard phase dimming wired for reverse phase)

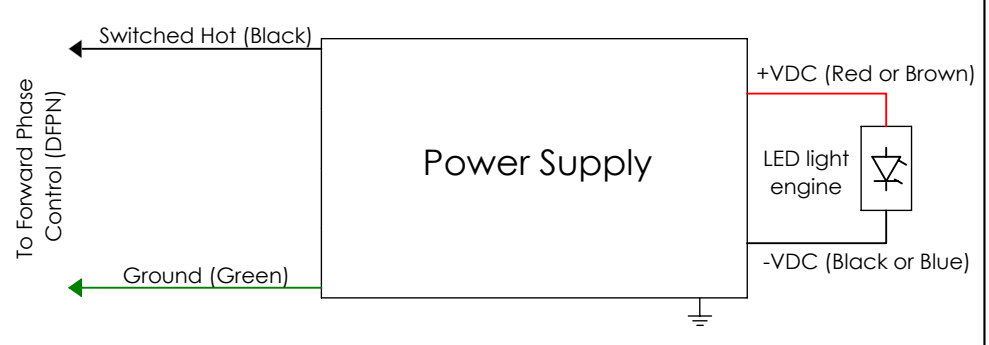

PEQ1 1%/PEQ0 0.1% Dimming

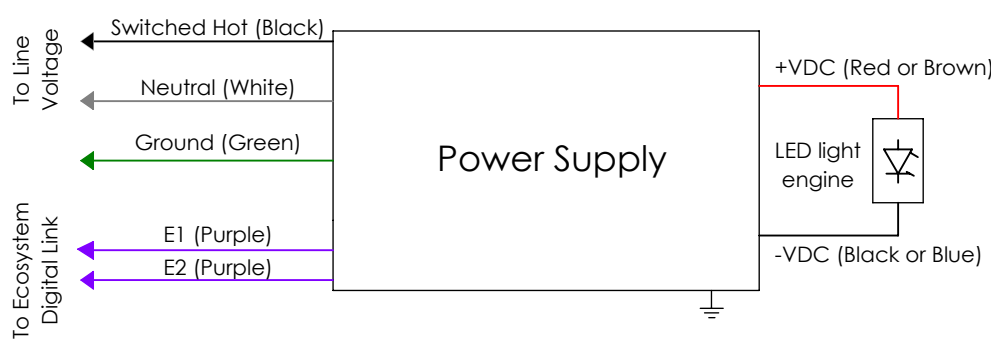

0-10V Dimming

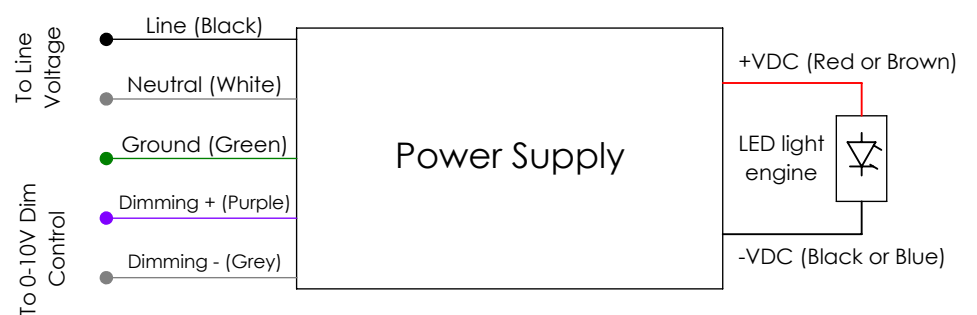

ALL SHOWN DRIVERS ARE INTER-LUX PROVIDED. FOR NON INTER-LUX PROVIDED DRIVERS PLEASE REFER TO DRIVER MANUFACTURER. THE USE OF NON INTER-LUX PROVIDED DRIVERS VOIDS PRODUCT WARRANTY.