

Constant Voltage drivers

Wiring Key Points

1. This product shall be installed by a qualified electrician.
2. Make sure the main power supply to the driver is turned off when wiring either the LEDs or driver.
3. LEDs shall be wired in parallel as shown in wiring diagram. CAUTION: incorrect wiring may damage LEDs.
4. Wire shall be #18AWG stranded minimum. Large gauge wire shall be used to limit voltage drop in order to maintain the proper operating voltage. Take every precaution to avoid interference from other electrical circuits and equipment.
5. Dimming circuits are more sensitive to voltage drop and electrical interference from other electrical sources.
6. Isolating LED wiring by dedicated circuit for each control zone is recommended.
7. Contractor shall verify the fixture quantities connected to the driver are compatible with the driver's specifications prior to energizing the circuit.
8. All Class II power cable remote wiring by others.

LED's can be permanently damaged if these points are not followed

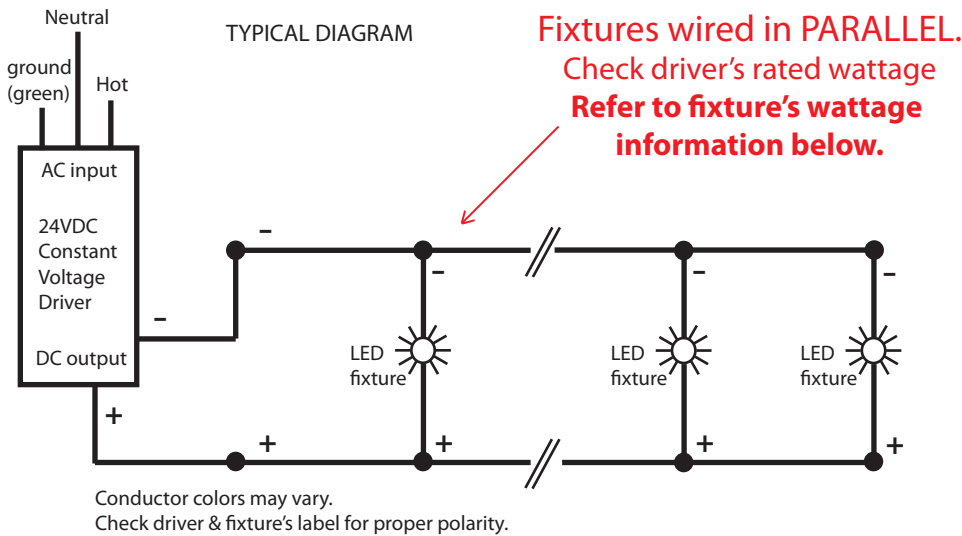

Maximum wiring distance*

Wire gauge	Load per driver		
	≤48W	≤72W	≤96W
#18AWG	37'	25'	18'
#16AWG	59'	39'	29'
#14AWG	95'	63'	47'
#12AWG	151'	101'	75'
#10AWG	241'	160'	120'

* Voltage drop guide for 24VDC. Actual Voltage drop to be calculated by installer.

Fixture

Nominal Length

Watts/fixture

PLEASE NOTE: LUTRON CONSTANT VOLTAGE DRIVERS REQUIRE A MINIMUM LOAD OF 5 WATTS

inter•lux

Project:	Type:	Date:
Manufacturer: LINEALIGHT	Fixture:	Page: 1 OF 10

Hi-lume 1% 2-Wire LED Driver Forward-Phase Control Overview

The Hi-lume 1% 2-Wire LED Driver is a high-performance LED driver that provides smooth, continuous, flicker-free, 1% dimming for virtually any LED fixture, whether it requires constant-current or constant-voltage. Formerly part of the A-series family, it is the most versatile LED driver offered today due to its compatibility with a wide variety of LED arrays, multiple form factors, and numerous control options.

Features

- UL® Listed Class P
- Continuous, flicker-free dimming from 100% to 1%.¹
- Guaranteed compatibility with selected Maestro Wireless, RadioRA 2, HomeWorks QS, GRAFIK Eye QS, GRAFIK Systems, Quantum, and C•L dimmers. Please see **Compatible Controls** chart or contact Lutron for details regarding compatible controls.
- QwikFig compatible. For more information please refer to Lutron P/N 041473 (K and M case only).
- 100% performance tested at factory.
- A rated lifetime of 50,000 hours @ $t_c = 149^\circ\text{F}$ (65°C).
- Remote-mount options for United States and Canada.
- NOM certified option for Mexico.
- Type TL Rated.²
- FCC Part 15 compliant for commercial and residential (UL® Listed, remote-mountable only) applications at 120 V ~.
- Pulse width modulation (PWM) or constant-current reduction (CCR) dimming methods available. See Application Note #360 for details.
- RoHS Compliant.
- ENERGY STAR Luminaires V2.0 and California Title 24 JA8 compliant models available.
- For more information please go to: www.lutron.com/hilume1led

¹ Light output at 1% depends on the efficacy of the light engine used with the driver.

² Visit "Online Certificates Directory" at www.ul.com, enter file number "E322469" to determine the Type TL numbers specific to LTE model Lutron LED Driver.

LUTRON SPECIFICATION SUBMITTAL

Job Name:	Model Numbers:		
<input type="text"/>	<input type="text"/>	<input type="text"/>	<input type="text"/>
Job Number:	<input type="text"/>	<input type="text"/>	<input type="text"/>



Case type K

3.00 in (76 mm) W x 1.00 in (25 mm) H x
4.90 in (124 mm) L



Case type M

1.18 in (30 mm) W x 1.00 in (25 mm) H x
14.25 in (362 mm) L



Case type KL

K-case mounted on a 4.00 in (102 mm) W x
1.50 in (38 mm) H x 4.00 in (102 mm) L junction
box to provide wiring compartment

Specifications

Regulatory Approvals

- Meets ANSI C62.41 category A surge protection standards up to and including 4 kV.
- FCC Part 15 compliant for commercial and residential (UL® Listed, remote-mountable only) applications.
- Manufacturing facilities employ ESD reduction practices that comply with the requirements of ANSI/ESD S20.20.
- Lutron Quality Systems registered to ISO 9001.2015.
- UL® 8750 Class P Listed (K- and M- cases).
- UL® 8750 Listed, remote-mountable form factor (KL Case).
- Class 2 output available.
- LTEA4U1UKL-AV120 and LTEA4U1UKL-CV240 models are NOM certified and available for Mexico.
- LED drivers need to meet certain performance criteria in order for the completed luminaires to comply with the ENERGY STAR Luminaires V2.0 Specification. All models meet these performance criteria throughout their entire load compatibility regions. Refer to the load compatibility graph on each output range page. Consult Application Note #599, **ENERGY STAR Luminaires V2.0 and Lutron Drivers** at www.lutron.com for availability dates of compliant products.
- LED drivers need to meet certain performance criteria in order for the completed luminaires to comply with Title 24 requirements as detailed in CEC-400-2015-037-CMF. All models meet these performance criteria above a minimum output power in their compatibility regions. Refer to the load compatibility graph on each output range page for specific details. Consult **CEC-400-2015-032-CMF Section 6.2.7** for important information on meeting start-up time requirements with fade-in lighting.

UL® 8750 Listed, Remote-Mountable Option

- cULus for United States and Canada available for certain operating regions.
- Pre-wired and installation ready.
- See **KL Case: Case Dimensions** page for more specific details regarding UL listed option.
- Integral junction box to save time.
- For maximum driver-to-LED light engine wire length, see **Driver Leads** section near the end of this document.

Environmental

- Sound Rating: Inaudible in 27 dB ambient.
- Relative Humidity: Maximum 90% non-condensing.
- Minimum operating ambient temperature $t_a = 32\text{ }^\circ\text{F}$ ($0\text{ }^\circ\text{C}$).¹

¹ Where t_a is the temperature of the air directly surrounding the driver.

Job Name: <input style="width: 90%; height: 20px;" type="text"/>	Model Numbers: <input style="width: 90%; height: 20px;" type="text"/>	
Job Number: <input style="width: 80%; height: 20px;" type="text"/>	<input style="width: 90%; height: 20px;" type="text"/>	<input style="width: 90%; height: 20px;" type="text"/>

Specifications *(continued)*

Performance

- Dimming Range: 100% to 1%.
- Operating Voltage: 120 V~ at 50/60 Hz
- Requires Forward Phase Control; please see **Compatible Controls** chart.
- A rated lifetime of 50,000 hours @ $t_c = 149^\circ\text{F}$ (65°C).
 - For rated warranty, t_c not to exceed the maximum rated temperatures.¹
- Patented thermal foldback protection.
- At turn-on, lighting will fade smoothly to the desired light level without decreasing or flashing to full brightness.
- Non-volatile memory restores all driver settings after power failure.
- Inrush Current: < 2 A.
- Inrush Current Limiting Circuitry: eliminates circuit breaker tripping, switch arcing and relay failure.
- Open circuit protected.
- Short circuit protected.
- Turn-on time: ≤ 0.5 seconds to first light.
- PWM Dimming Frequency: 550 Hz.²

Driver Wiring & Mounting

- Driver is grounded by a mounting screw to the grounded fixture (or by terminal connection on the K case).
- Terminal blocks on the driver accept one solid wire per terminal from 18 AWG to 16 AWG (0.75 mm^2 to 1.5 mm^2).
- Fixture must be grounded in accordance with local and national electrical codes.
- For maximum driver-to-LED light engine wire length, see charts in **Driver Leads** section at the end of the document.

¹ Installer is responsible for ensuring that the driver case temperature does not exceed the maximum rated temperature.

² Does not apply to CCR dimming method drivers.

Job Name: <input style="width: 90%; height: 20px;" type="text"/>	Model Numbers: <input style="width: 60%; height: 20px;" type="text"/> <input style="width: 35%; height: 20px;" type="text"/>	
Job Number: <input style="width: 80%; height: 20px;" type="text"/>	<input style="width: 30%; height: 20px;" type="text"/>	<input style="width: 30%; height: 20px;" type="text"/>

How to Build a Model Number: Hi-lume 1% 2-Wire LED Driver

LTEA4U1U K L - C V 240 = Inter-lux part #
LUT40-24V-DFPN

Example: LTEA4U1UKS-HC070

For further assistance selecting your model number, contact our LED Center of Excellence at 1.877.DIM.LED8 or LEDs@lutron.com

Case Size:

- K** = Compact
- M = Stick

Current Level (for Constant-Current):

020 = 0.20 A; 021 = 0.21 A...070 = 0.70 A...210 = 2.10 A

Voltage Level (for Constant-Voltage):

100 = 10.0 V; 105 = 10.5 V...600 = 60.0 V

Case Style:

- S = Studded (K case only)
- N = Non-Studded
- L** = Remote-mountable, (K case only)

Driver Output:

- C = Constant-current driver with pulse width modulation (PWM) dimming
- A = Constant-current driver with constant-current reduction (CCR) dimming
- V** = Constant-voltage driver with pulse width modulation (PWM) dimming

LED Load Output Range (see the following pages for more detail):

Class 2 Constant-Voltage

- A = 10.0 V–12.0 V*
- B = 12.5 V–20.0 V*†
- C** = 20.5 V–24.0 V†
- D = 24.5 V–38.0 V†

Isolated Non-Class 2 Constant-Voltage

- X = 38.5 V–60.0 V†

Class 2 Constant-Current

- E = 0.20 A–0.50 A 30 V–54 V
- F = 0.51 A–1.00 A 30 V–54 V†
- G = 0.20 A–0.70 A 8 V–20 V
- H = 0.20 A–0.70 A 15 V–38 V
- I = 0.71 A–1.05 A 8 V–20 V
- J = 0.71 A–1.05 A 15 V–38 V
- K = 1.06 A–1.50 A 8 V–20 V
- L = 1.06 A–1.50 A 15 V–38 V†
- M = 1.51 A–2.10 A 8 V – 19.9 V†

Isolated Non-Class 2 Constant-Current

- Y = 0.20 A–0.50 A 30 V–60 V
- Z = 0.51 A–1.00 A 30 V–60 V†

* Available in K-case only.

† Output parameter is power-limited for these output ranges. Consult detailed specifications on the following pages for each range.

Job Name: <input type="text"/>	Model Numbers: <input type="text"/>	
Job Number: <input type="text"/>	<input type="text"/>	<input type="text"/>

“C” Output Range, Voltage Driver Models

Driver Type	Output Dimming Method	Output Voltage	Output Current	Output Power	Standards Recognition	UL® Listed, Remote-Mountable Available	Standards Recognition for UL® Listed, Remote-Mountable
Constant-Voltage Driver (Class 2)	Pulse Width Modulation (PWM)	20.5–24.0 V PWM	0.21–1.95 A	5–40 W	UL US LISTED CLASS P E322409	Yes	UL US LISTED NOM ¹

Typical Performance Specifications:

Parameter	Value	Test Conditions
Input Current	420 mA	t _a = 25 °C, 24.0 V 40 W load, Maximum Light Output, K case 120 V~ without a dimmer
Power Factor	0.98	
THD	14%	
Driver Efficiency	80%	

Load Compatibility

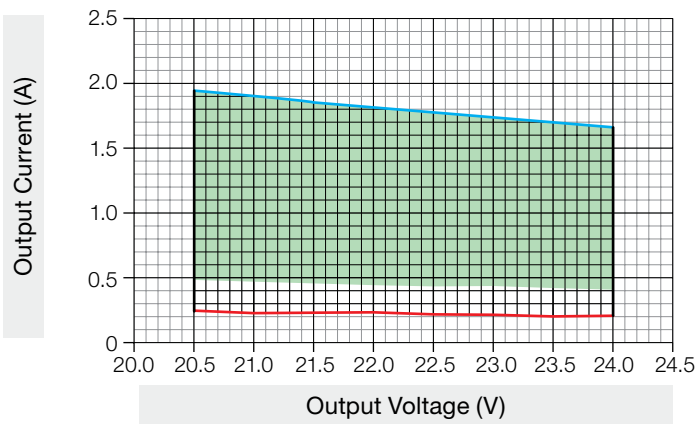

Key:
■ Green area shows California Title 24
— 5 W limited — 40 W limited

Typical Efficiency vs. Output Voltage

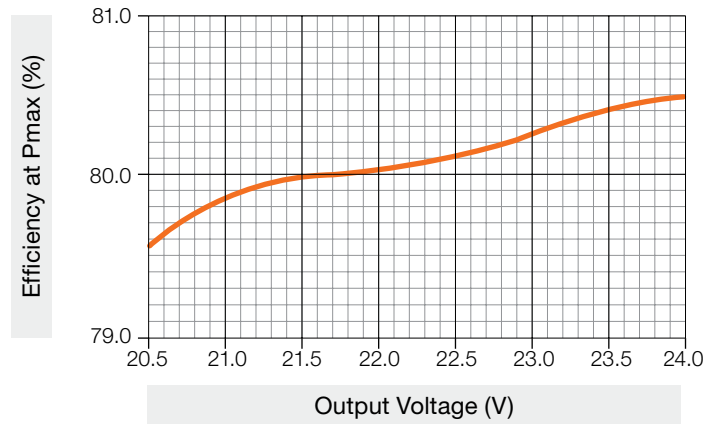

Typical THD vs. Output Power

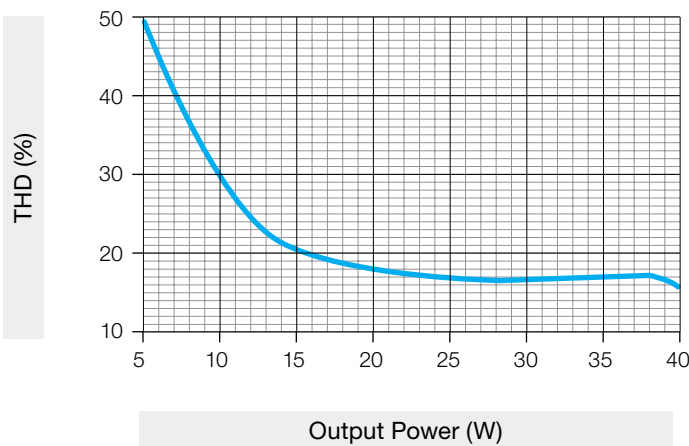

Typical Power Factor vs. Output Power

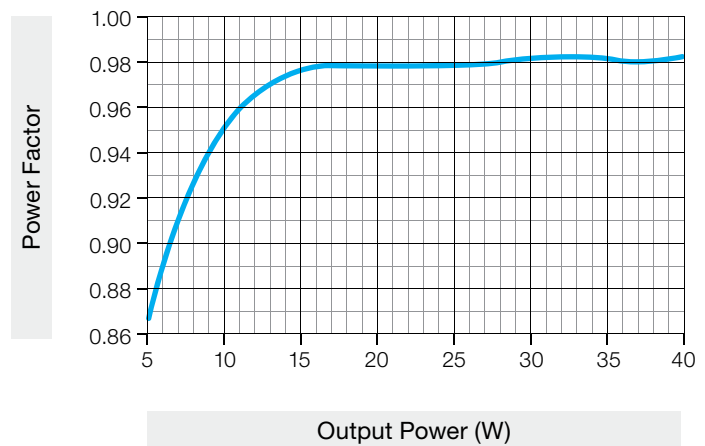

¹ LTEA4U1UKL-AV120 and LTEA4U1UKL-CV240 models are NOM certified and available for Mexico.

Job Name: <input style="width: 90%; height: 20px;" type="text"/>	Model Numbers: <input style="width: 95%; height: 20px;" type="text"/>
Job Number: <input style="width: 80%; height: 20px;" type="text"/>	<input style="width: 95%; height: 20px;" type="text"/>

UL® Listed, Remote-Mountable: Case Dimensions

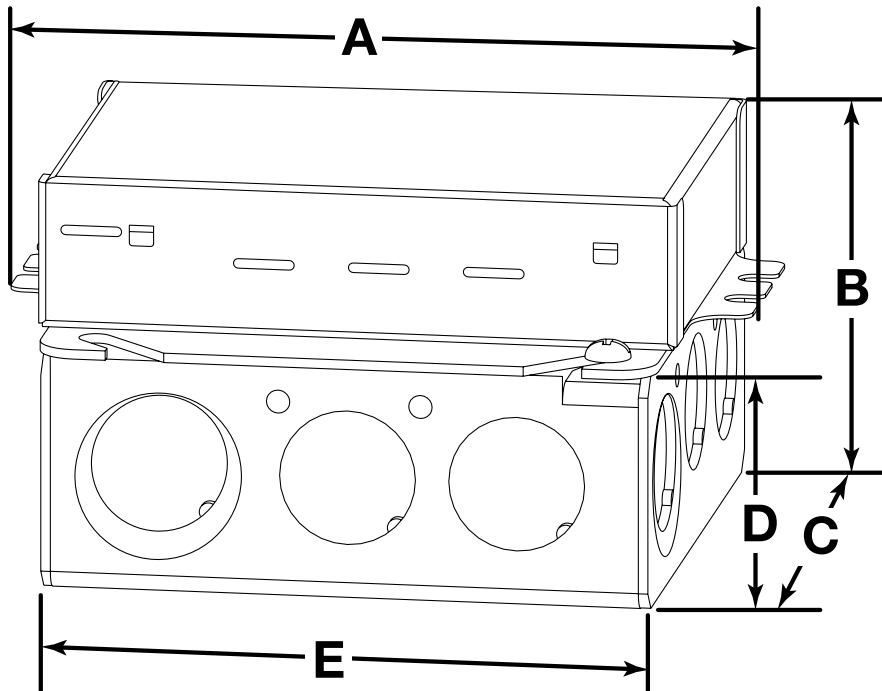

A	4.89 in (124 mm)
B	2.62 in (66 mm)
C	4.00 in (102 mm)
D	1.62 in (41 mm)
E	4.00 in (102 mm)

KL case includes a 4 in (102 mm) square junction box which complies with NEMA OS 1-2008 Figure 112.

Knockouts

- Sides
 - 8 locations: 0.5 in (13 mm)
 - 4 locations: 0.5/0.75 in (13/19 mm)
- Bottom
 - 2 locations: 0.5 in (13 mm)
 - 2 locations: 0.5/0.75 in (13/19 mm)

Driver Wiring and Mounting

- Driver is grounded by the green ground wire connection on the enclosure or by the ground lug terminal in the junction box
- Driver and junction box must be grounded in accordance with local and national electrical codes
- All wire connections must be made in the junction box to maintain UL® listing
- 4 in (102 mm) square junction box is 1.5 in (38 mm) deep with 22.0 in³ (360.5 cm³) capacity and complies with NEMA OS 1-2008 Figure 112
- Driver is pre-wired with 6 in (152 mm), 18 AWG (0.75 mm²) solid copper leads in all terminal blocks

Job Name:	Model Numbers:	
<input type="text"/>	<input type="text"/>	<input type="text"/>
Job Number:	<input type="text"/>	<input type="text"/>

UL® Marking and Compatibility

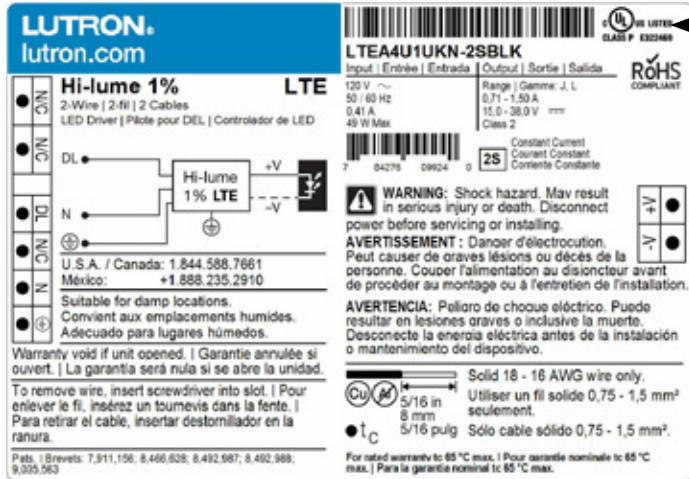

Location of the standards mark on the driver.



Drivers marked as UL® recognized are ONLY compatible with those controls marked with an asterisk (*) on the following pages.



Drivers marked as UL® Listed Class P are compatible with all controls referenced on the following pages.



Drivers marked as UL® 8750 Listed and manufactured before November 20, 2017, are ONLY compatible with those controls marked with an asterisk (*) on the following pages. Date code on the driver is in international date format, DD/MM/YYYY.

Note: If the fixture or driver is not accessible and the standards marking is unknown, use controls marked with an asterisk (*).

Wiring

Controls Requiring Neutral

Note: Colors shown correspond to terminals on driver.

Wiring Diagram

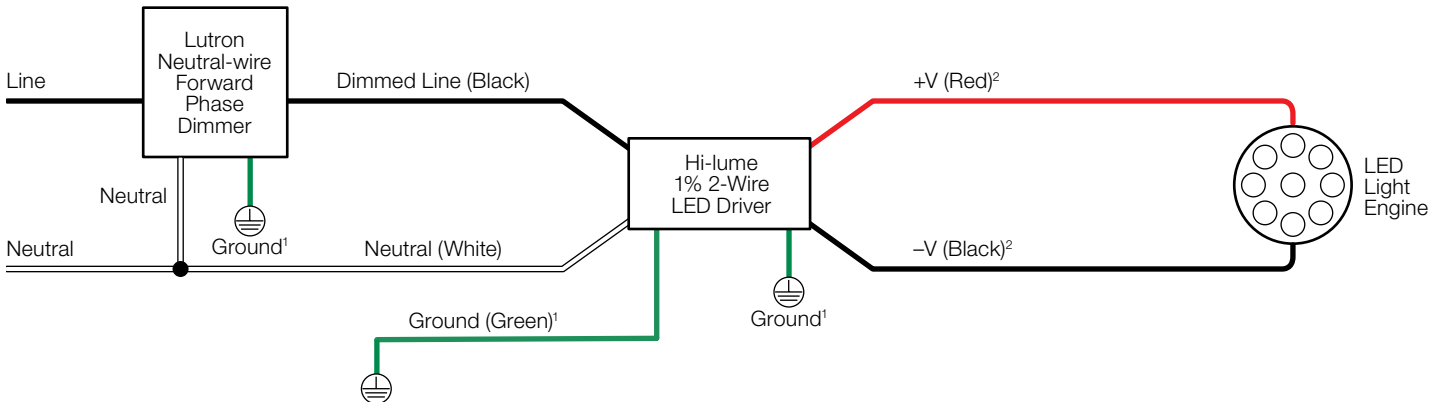

¹Ground wire connection available on K case models only. Fixture and driver case must be grounded in accordance with local and national electrical codes.

²For maximum driver-to-LED light engine wire length, see charts in **Driver Leads** section at the end of the document.

Job Name:	Model Numbers:	
<input type="text"/>	<input type="text"/>	<input type="text"/>
Job Number:	<input type="text"/>	<input type="text"/>

Wiring (continued)

Controls Requiring Neutral (continued)

Compatible Controls: Lutron Neutral-wire Dimmers

Guaranteed performance specifications with the controls listed in the chart below.

For assistance selecting controls, contact our LED Center of Excellence at 1.877.DIM.LED8 or LEDs@lutron.com

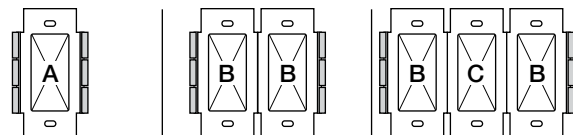

Product	Part Number	Low-End Setting/ Load-Type Setting ¹	Drivers per Control		
			A: Not Ganged	B: End of Gang	C: Middle of Gang
RadioRA 2 adaptive dimmer*	RRD-6NA-	Hi-lume 1% 2-Wire LTE LED ²	1–10, 400 W max	1–10, 400 W max	1–10, 400 W max
RA2 Select/RadioRA 2 600 W dimmer	RRD-6ND	Hi-lume 1% 2-Wire LTE LED ²	1–8, 350 W max	1–8, 350 W max	1–8, 350 W max
RadioRA 2 1000 W dimmer*	RRD-10ND-	Set Device type to “INC/MLV Neutral Dimmer”; Set High-End Trim to 99%; Set Low-End Trim to 35%	1–13	1–13	1–13
RadioRA 2 Architectural RF GRAFIK T phase selectable dimmer	RRT-G5NEW-	Trim low-end per APM App Note (Lutron P/N 048534)	1–10, 400 W max	1–10, 400 W max	1–10, 400 W max
RadioRA 2 Architectural RF GRAFIK T dimmer	RRT-G25LW-	Trim low-end per APM App Note (Lutron P/N 048534)	1–10, 400 W max	1–10, 400 W max	1–10, 400 W max
RadioRA 2 C•L hybrid seeTouch keypad	RRD-HN	Hi-lume 1% 2-Wire LTE LED	1–10, 200 W max	1–10, 200 W max	1–10, 200 W max
RadioRA 2 GRAFIK T C•L hybrid keypad	RRT-GH	Hi-lume 1% 2-Wire LTE LED	1–10, 400 W max	1–10, 400 W max	1–10, 400 W max
HomeWorks QS adaptive dimmer*	HQRD-6NA-	Hi-lume 1% 2-Wire LTE LED ²	1–10, 400 W max	1–10, 400 W max	1–10, 400 W max
HomeWorks QS 600 W dimmer*	HQRD-6ND-	Hi-lume 1% 2-Wire LTE LED ²	1–8, 350 W max	1–8, 350 W max	1–8, 350 W max
HomeWorks QS 1000 W dimmer*	HQRD-10ND-	Hi-lume 1% 2-Wire LTE LED ²	1–13	1–13	1–13
Maestro Wireless 600 W dimmer*	MRF2-6ND-120-	Trim low-end per APM App Note (Lutron P/N 048370)	1–8, 350 W max	1–8, 350 W max	1–8, 350 W max
Vive Maestro Wireless 600 W dimmer*	MRF2S-6ND-120-	Trim low-end per APM App Note (Lutron P/N 048370)	1–8, 350 W max	1–8, 350 W max	1–8, 350 W max
HomeWorks QS GRAFIK T hybrid keypad	HQRT-GH	Hi-lume 1% 2-Wire LTE LED	1–10, 400 W max	1–10, 400 W max	1–10, 400 W max
HomeWorks QS Architectural GRAFIK T dimmer	HQRT-G25LW-	Hi-lume 1% 2-Wire LTE LED	1–10, 400 W max	1–10, 400 W max	1–10, 400 W max
HomeWorks QS Architectural GRAFIK T phase selectable dimmer	HQRT-G5NEW-	Hi-lume 1% 2-Wire LTE LED	1–10, 400 W max	1–10, 400 W max	1–10, 400 W max
HomeWorks QS designer C•L hybrid seeTouch keypad	HQRD-HN	Hi-lume 1% 2-Wire LTE LED	1–10, 200 W max	1–10, 200 W max	1–10, 200 W max
GRAFIK T C•L 250 W dimmer*	GT-250M-, GTJ-250M-	Set low-end trim per dimmer installation instructions	1–10, 400 W max	1–10, 400 W max	1–10, 400 W max
Caséta Wireless Pro 1000 W dimmer*	PD-10NXD-	Trim low-end per instructions at www.casetawireless.com/lowend	1–13	1–13	1–13
Caséta Wireless phase selectable dimmer	PD-5NE-	Trim low-end per instructions at www.casetawireless.com/lowend	1–20, 400 W max	1–20, 400 W max	1–20, 400 W max

Note: All wattages are in terms of input wattage to the LED driver.

* See note on page 35 for control compatibility.

¹ Setting the low-end trim and load type is necessary to ensure optimal performance and 1% dimming capability.

Note: For information about Legacy Product use in existing control application, contact LEDs@lutron.com

² Also listed as “LED Lutron A-Series 2-Wire” or “Hi-lume A-Series LTE LED Driver 2-Wire” in previous software releases.

Job Name:	Model Numbers:	
<input type="text"/>	<input type="text"/>	<input type="text"/>
Job Number:	<input type="text"/>	<input type="text"/>

Wiring (continued)

Controls Requiring Neutral (continued)

Note: Colors shown correspond to terminals on driver.

Wiring Diagram

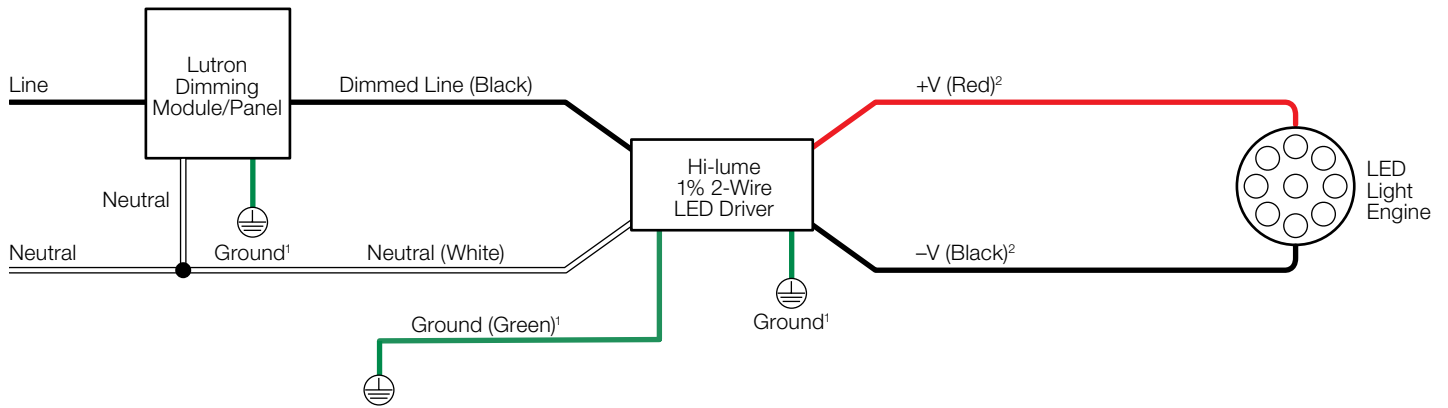

¹ Ground wire connection available on K case models only. Fixture and driver case must be grounded in accordance with local and national electrical codes.

² For maximum driver-to-LED light engine wire length, see charts in **Driver Leads** section at the end of the document.

Compatible Controls: Lutron Dimming Modules/Panels

Guaranteed performance specifications with the controls listed in the chart below.

For assistance selecting controls, contact our LED Center of Excellence at 1.877.DIM.LED8 or LEDs@lutron.com

Product	Part Number	Drivers per Control	Low-End Setting/Load-Type Setting ¹
myRoom DIN power module*	MQSE-4A1-D	1–6 (per output); 1 A maximum driver input current	Hi-lume 1% 2-Wire LTE LED ²
HomeWorks QS DIN power module*	LQSE-4A1-D	1–6 (per output); 1 A maximum driver input current	Hi-lume 1% 2-Wire LTE LED ²
HomeWorks QS Phase Adaptive DIN pwr module	LQSE-4A-120-D	1–6 (per output); 2 A maximum driver input current	Hi-lume 1% 2-Wire LTE LED ²
HomeWorks QS wallbox power module*	HQRJ-WPM-6D-120	2–10 (per output); 26 total per module	Hi-lume 1% 2-Wire LTE LED ²
HomeWorks wallbox power module*	HWI-WPM-6D-120	2–10 (per output); 26 total per module	Set load type to “GRX-FDBI” or “GRX-TVI”
GRAFIK Eye QS control unit*	QSGR-, QSGRJ-	2–10 (per output); 26 total per unit	Set load type to “Fluorescent Module”
GRAFIK Eye 3000 control unit*	GRX-3100-, GRX-3500-	2–10 (per output); 26 total per module	Set load type to “GRX-FDBI” or “GRX-TVI”
RPM-4U module (LCP, HomeWorks QS, GRAFIK Systems, Quantum)*	HW-RPM-4U-120, LP-RPM-4U-120	2–26 (per output); 26 total per module	Hi-lume 1% 2-Wire LTE LED ² Set load type to “2-1”
RPM-4A module (LCP, HomeWorks QS, GRAFIK Systems, Quantum)*	HW-RPM-4A-120, LP-RPM-4A-120	1–13 (per output); 26 total per module	Hi-lume 1% 2-Wire LTE LED ² Set load type to “2-1”
GP dimming panels*	Various	1–26	Set load type to “2-1”

* See note on page 35 for control compatibility.

¹ Setting the low-end trim and load type is necessary to ensure optimal performance and 1% dimming capability.

² Also listed as “LED Lutron A-Series 2-Wire” or “Hi-lume A-Series LTE LED Driver 2-Wire” in previous software releases.

Job Name: <input type="text"/>	Model Numbers: <input type="text"/>
Job Number: <input type="text"/>	<input type="text"/>

Wiring (continued)

Controls Not Requiring Neutral

Note: Colors shown correspond to terminals on driver.

Wiring Diagram

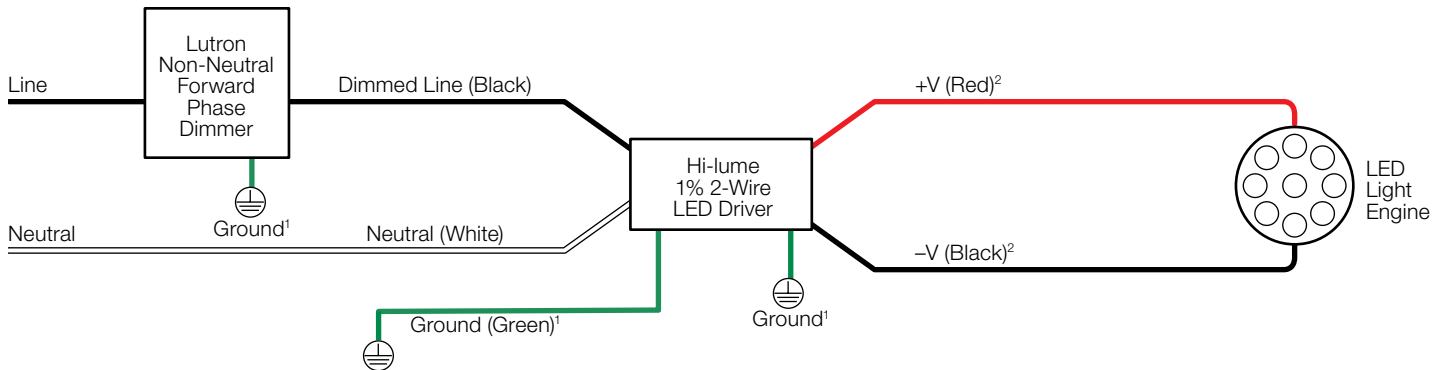

¹ Ground wire connection available on K case models only. Fixture and driver case must be grounded in accordance with local and national electrical codes.

² For maximum driver-to-LED light engine wire length, see charts in **Driver Leads** section at the end of the document.

Compatible Controls: Lutron Non-Neutral Dimmers

Guaranteed performance specifications with the controls listed in the chart below.

For assistance selecting controls, contact our LED Center of Excellence at 1.877.DIM.LED8 or LEDs@lutron.com

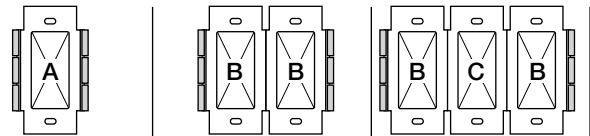

Product	Part Number	Low-End Setting/Load-Type Setting ¹	Drivers per Control		
			A: Not Ganged	B: End of Gang	C: Middle of Gang
Ariadni C•L 250 W dimmer*	AYCL-253P-	Set low-end trim dial to 1 o'clock. Adjust slightly if needed. See dimmer installation instructions on how to adjust low-end trim.	1-8, 350 W max	1-8, 350 W max	1-8, 350 W max
Ariadni C•L 150 W dimmer	TGCL-153P, AYCL-153P-	Set low-end trim dial to 1 o'clock. Adjust slightly if needed. See dimmer installation instructions on how to adjust low-end trim.	1-6, 250 W max	1-6, 250 W max	1-6, 250 W max
Diva C•L 250 W dimmer*	DVCL-253P- DVSCCL-253P-	Set low-end trim dial to 10 o'clock. Adjust slightly if needed. See dimmer installation instructions on how to adjust low-end trim.	1-8, 350 W max	1-8, 350 W max	1-8, 350 W max
Diva C•L 150 W dimmer	DVCL-153P-, DVSCCL-153P-	Set low-end trim dial to 10 o'clock. Adjust slightly if needed. See dimmer installation instructions on how to adjust low-end trim.	1-6, 250 W max	1-6, 250 W max	1-6, 250 W max
Nova T★ C•L 250 W dimmer*	NTCL-250-	Set low-end trim dial to 10 o'clock. Adjust slightly if needed. See dimmer installation instructions on how to adjust low-end trim.	1-10, 400 W max	1-10, 400 W max	1-10, 400 W max
Lumea C•L 150 W dimmer	LECL-153P-	Set low-end trim dial to 10 o'clock. Adjust slightly if needed. See dimmer installation instructions on how to adjust low-end trim.	1-6, 250 W max	1-6, 250 W max	1-6, 250 W max
Skylark C•L 150 W dimmer	SCL-153P-	Set low-end trim dial to 10 o'clock. Adjust slightly if needed. See dimmer installation instructions on how to adjust low-end trim.	1-6, 250 W max	1-6, 250 W max	1-6, 250 W max
Contour C•L 150 W dimmer	CTCL-153P-	Set low-end trim dial to 10 o'clock. Adjust slightly if needed. See dimmer installation instructions on how to adjust low-end trim.	1-6, 250 W max	1-6, 250 W max	1-6, 250 W max

Note: All wattages are in terms of input wattage to the LED driver.

* See note on page 35 for control compatibility.

¹ Setting the low-end trim and load type is necessary to ensure optimal performance and 1% dimming capability.

Note: For information about Legacy Product use in existing control application, contact LEDs@lutron.com

Job Name:	Model Numbers:	
<input type="text"/>	<input type="text"/>	<input type="text"/>
Job Number:	<input type="text"/>	<input type="text"/>

Wiring (continued)

Controls Not Requiring Neutral (continued)

Compatible Controls: Lutron Non-Neutral Dimmers

Guaranteed performance specifications with the controls listed in the chart below.

For assistance selecting controls, contact our LED Center of Excellence at 1.877.DIM.LED8 or LEDs@lutron.com

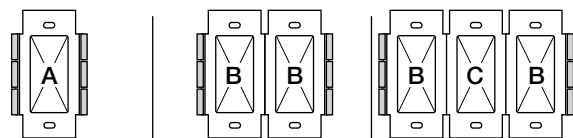

Product	Part Number	Low-End Setting/Load-Type Setting ¹	Drivers per Control		
			A: Not Ganged	B: End of Gang	C: Middle of Gang
Maestro C•L 150 W dimmer	MACL-153M-	Trim low-end per APM App Note (Lutron P/N 048370)	1–6, 250 W max	1–6, 250 W max	1–6, 250 W max
Maestro C•L 150 W sensor	MSCL-OP153M-, MSCL-VP153M-	Trim low-end per APM App Note (Lutron P/N 048370)	1–6, 250 W max	1–6, 250 W max	1–6, 250 W max
Vive Maestro C•L 150 W dimmer	MRF2S-6CL-	Trim low-end per APM App Note (Lutron P/N 048370)	1–6, 250 W max	1–6, 250 W max	1–6, 250 W max
GRAFIK T C•L 150 W dimmer	GTJ-150-	Set low-end trim per dimmer installation instructions	1–6, 250 W max	1–6, 250 W max	1–6, 250 W max
Maestro Wireless C•L 150 W dimmer	MRF2-6CL-	Trim low-end per APM App Note (Lutron P/N 048370)	1–6, 250 W max	1–6, 250 W max	1–6, 250 W max
RadioRA 2 C•L 150 W dimmer	RRD-6CL-	Set low-end trim per dimmer installation instructions	1–6, 250 W max	1–6, 250 W max	1–6, 250 W max
HomeWorks QS Designer C•L 150 W dimmer	HQRD-6CL-	Hi-lume 1% 2-Wire LTE LED	1–6, 250 W max	1–6, 250 W max	1–6, 250 W max
Caséta Wireless C•L Dimmer	PD-6WCL-	Trim low-end per instructions at www.casetawireless.com/lowend	1–6, 250 W max	1–6, 250 W max	1–6, 250 W max
RadioRA 2 Architectural RF GRAFIK T dimmer ²	RRT-G25LW-	Trim low-end per APM App Note (Lutron P/N 048534)	1–10, 400 W max	1–10, 400 W max	1–10, 400 W max
HomeWorks QS Architectural GRAFIK T dimmer ²	HQRT-G25LW-	Hi-lume 1% 2-Wire LTE LED	1–10, 400 W max	1–10, 400 W max	1–10, 400 W max
GRAFIK T C•L 250 W dimmer ^{* 2}	GT-250M-, GTJ-250M-	Set low-end trim per dimmer installation instructions	1–10, 400 W max	1–10, 400 W max	1–10, 400 W max

Note: All wattages are in terms of input wattage to the LED driver.

* See note on page 35 for control compatibility.

¹ Setting the low-end trim and load type is necessary to ensure optimal performance and 1% dimming capability.

Note: For information about Legacy Product use in existing control application, contact LEDs@lutron.com

² Minimum number of drivers for GRAFIK T will vary based on the number of companion dimmers (model number GT-AD) connected. Refer to the GRAFIK T Spec Submittal, Lutron P/N 369826, at www.lutron.com This only applies when neutral is not connected.

Job Name:	Model Numbers:	
<input type="text"/>	<input type="text"/>	<input type="text"/>
Job Number:	<input type="text"/>	<input type="text"/>

Terminal Wiring Gauges

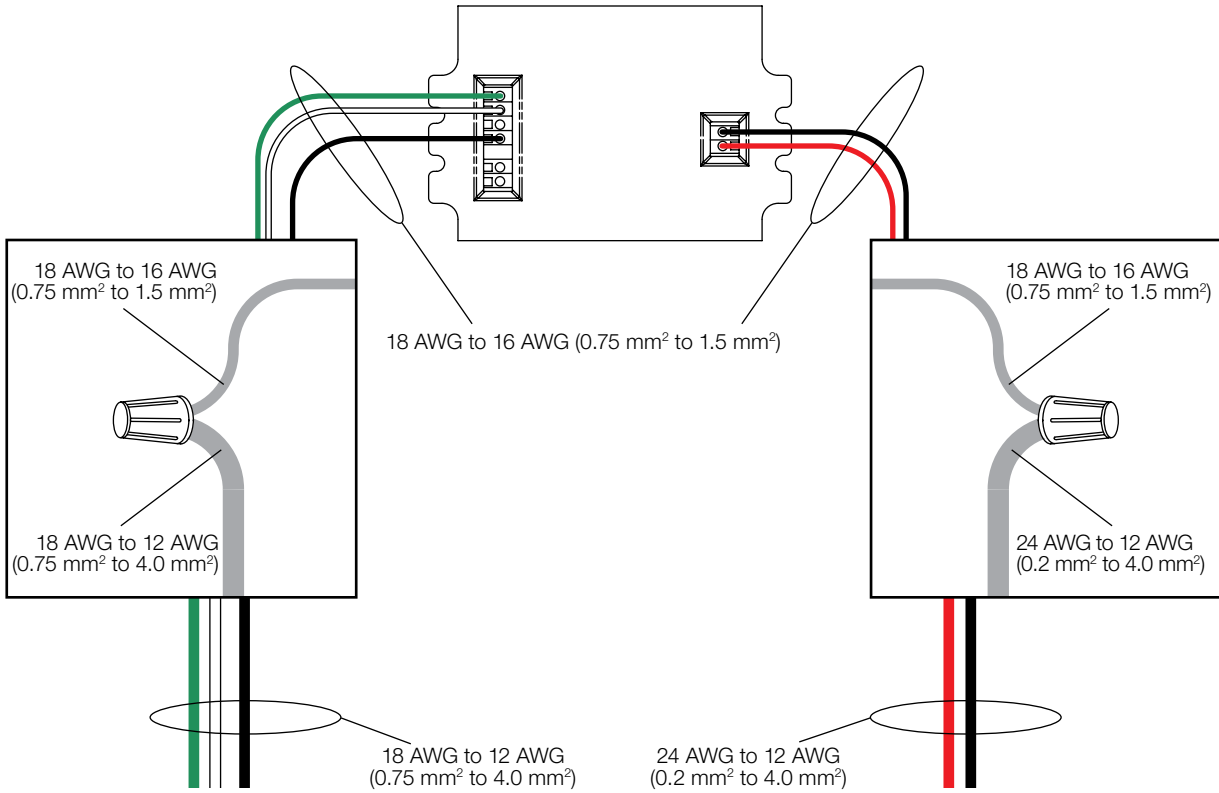

Note: Colors shown correspond to terminal blocks on driver.

Job Name:	Model Numbers:	
<input type="text"/>	<input type="text"/>	<input type="text"/>
Job Number:	<input type="text"/>	<input type="text"/>

Electricians and Contractors

Driver Leads

Maximum driver-to-LED light engine wire length for
Constant-Current Drivers:

Wire Gauge*	Maximum Lead Length		
	200 mA to 700 mA	710 mA to 1.50 A	1.51 A to 2.10 A
24 AWG (0.2 mm ²)	8 ft (2.5 m)	4 ft (1.2 m)	2.75 ft (0.8 m)
22 AWG (0.34 mm ²)	13 ft (4 m)	6 ft (1.8 m)	4.5 ft (1.5 m)
20 AWG (0.5 mm ²)	20 ft (6 m)	10 ft (3 m)	7 ft (2 m)
18 AWG (0.75 mm ²)	30 ft (9 m)	15 ft (4.5 m)	10 ft (3 m)
16 AWG (1.5 mm ²)	35 ft (10.5 m)	25 ft (7.5 m)	15 ft (4.5 m)
14 AWG (2.5 mm ²)	50 ft (15 m)	40 ft (12 m)	25 ft (7.5 m)
12 AWG (4.0 mm ²)	100 ft (30 m)	60 ft (18 m)	40 ft (12 m)

Maximum driver-to-LED light engine wire length for
Constant-Voltage Drivers:

Wire Gauge*	Maximum Lead Length		
	10 V to 20 V	20.5 V to 40 V	40.5 V to 60 V
24 AWG (0.2 mm ²)	2.5 ft (0.8 m)	4 ft (1.2 m)	8 ft (2.5 m)
22 AWG (0.34 mm ²)	4 ft (1.2 m)	6 ft (1.8 m)	12 ft (3.7 m)
20 AWG (0.5 mm ²)	6 ft (1.8 m)	10 ft (3 m)	20 ft (6 m)
18 AWG (0.75 mm ²)	10 ft (3 m)	15 ft (4.5 m)	30 ft (9 m)
16 AWG (1.5 mm ²)	15 ft (4.5 m)	25 ft (7.5 m)	50 ft (15 m)
14 AWG (2.5 mm ²)	25 ft (7.5 m)	40 ft (12 m)	75 ft (22.5 m)
12 AWG (4.0 mm ²)	40 ft (12 m)	60 ft (18 m)	100 ft (30 m)

Terminal blocks on the drivers accept only solid 18 AWG or 16 AWG (0.75 mm² or 1.5 mm²) wire. To use wire gauges larger or smaller than this terminal blocks' rated gauge of 18 AWG or 16 AWG (0.75 mm² or 1.5 mm²) refer to the **Terminal Wiring Gauges** diagram on the previous page. Connect up to 3 ft (0.9 m) of 18 AWG or 16 AWG (0.75 mm² or 1.5 mm²) wire to the LED driver terminal blocks, then connect 14 AWG to 12 AWG (2.5 to 4.0 mm²) or 24 AWG to 20 AWG (0.20 mm² to 0.50 mm²) up to the length allowed in the above table.

Wiring and Grounding

Driver and lighting fixture must be grounded. Drivers must be installed per national and local electrical codes.

LED Load Replacement

For Class 2 rated drivers, the LED load can be changed while the driver is installed and powered.

Maximum Driver Operating Temperature

Driver case temperature (t_c) must not exceed UL conditions of acceptability in end product.

For 50,000 hour lifetime, driver case temperature (t_c) must not exceed 65 °C.

Job Name: <input style="width: 90%; height: 20px;" type="text"/>	Model Numbers: <input style="width: 95%; height: 20px;" type="text"/>	
Job Number: <input style="width: 80%; height: 20px;" type="text"/>	<input style="width: 95%; height: 20px;" type="text"/>	<input style="width: 95%; height: 20px;" type="text"/>

Facilities Managers

SERVICE

Warranty

For warranty information, please visit www.lutron.com/driverwarranty

Replacement Parts

When ordering Lutron replacement parts please provide the full model number. Consult Lutron Customer Assistance at 1.844.LUTRON1 if you have any questions.

Further Information

For further information, please visit us at www.lutron.com/hilume1led or contact our LED Control Center of Excellence at 1.877.DIM.LED8 or LEDs@lutron.com

EMC Information

This device complies with part 15 of the FCC Rules. Operation is subject to the following two conditions: (1) This device may not cause interference, and (2) this device must accept any interference, including interference that may cause undesired operation.

FOR UL LISTED CLASS P MODELS ONLY:

NOTE: This equipment has been tested and found to comply with the limits for a Class A digital device, pursuant to part 15 of the FCC rules. These limits are designed to provide reasonable protection against harmful interference when the equipment is operated in a commercial environment. This equipment generates, uses and can radiate radio frequency energy and, if not installed and used in accordance with the instruction manual, may cause harmful interference to radio communications. Operation of this equipment in a residential area is likely to cause harmful interference in which case the user will be required to correct the interference at his own expense.

Lutron,  Lutron, Hi-lume, C•L, Caséta, GRAFIK Eye, PowPak, Quantum, Lumea, Nova T⁺, Nova, Skylark, seeTouch, Diva, Ariadni, Maestro, Maestro Wireless, RadioRA, and HomeWorks are trademarks of Lutron Electronics Co., Inc., registered in the U.S. and other countries. Energi Savr Node, QwikFig, GRAFIK, GRAFIK Systems, GRAFIK T, myRoom, Vive, and RadioRA 2 are trademarks of Lutron Electronics Co., Inc.

UL and the UL logo are trademarks of UL LLC.

LUTRON SPECIFICATION SUBMITTAL

Job Name: <input type="text"/>	Model Numbers: <input type="text"/>	
Job Number: <input type="text"/>	<input type="text"/>	<input type="text"/>

FOR UL LISTED, REMOTE-MOUNTABLE MODELS ONLY:

NOTE: This equipment has been tested and found to comply with the limits for a Class B digital device, pursuant to part 15 of the FCC Rules. These limits are designed to provide reasonable protection against harmful interference in a residential installation. This equipment generates, uses and can radiate radio frequency energy and, if not installed and used in accordance with the instructions, may cause harmful interference to radio communications. However, there is no guarantee that interference will not occur in a particular installation. If this equipment does cause harmful interference to radio or television reception, which can be determined by turning the equipment off and on, the user is encouraged to try to correct the interference by one or more of the following measures:

- Reorient or relocate the receiving antenna.
- Increase the separation between the equipment and receiver.
- Connect the equipment into an outlet on a circuit different from that to which the receiver is connected.
- Consult the dealer or an experienced radio/TV technician for help.