

Tadpole

Installation and Maintenance Instructions

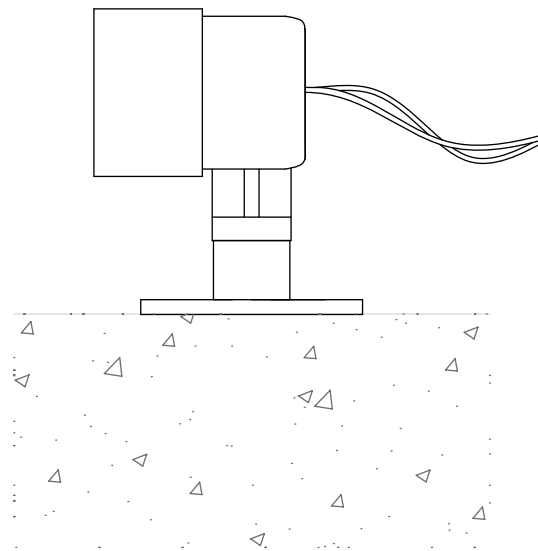

IMPORTANT: All wiring connections must be made before switching on mains power.

 MSL Star Oslos Square 2.9V_F 2W @ 700mA

IP66 Dust tight and protected against powerful jets of water.

 This product should not be disposed of in your general waste

 Please retain these instructions for future reference

 Class III - Extra Low Voltage

 Suitable for Exterior Use

 European Conformity

Electrical Supply

Installation must be carried out by a qualified electrician in accordance with BS 7671:2008 Wiring Regulations. 230/240V AC 50/60Hz mains supply to a suitable SELV LED Driver.

Site conditions: LED equipment is more susceptible to static damage and overvoltage than previous technology. Before handling or connecting to the mains supply ensure that all MSL products are protected from static discharge and that the mains supply is to regulation. (230V +10 -6%)

Mains cables must be double insulated, strain relieved and separated from E.L.V output cables.

Dimming control circuit source must be of SELV insulation class.

This unit requires a constant current driver. 700mA Max.

Observe polarity:
Positive (+) is marked as RED.
Incorrect supply or reverse polarity can cause irreparable damage.

All connections must be made before switching on mains. If the supply is energised prior to making the connections to the fitting then the resulting surge will damage the LED.

Multiple LEDs should be wired in series, refer to driver instructions for minimum/maximum load.

All lighting equipment is delicate and easily damaged through misuse or inappropriate installation (mechanical or electrical). Repairs and replacements may cause delays and will be chargeable. Contact MSL for support if required. For full warranty terms & conditions please visit our website.

The light source contained in this luminaire shall only be replaced by the manufacturer or his service agent or a similar qualified person.

Ensure supply driver and connectors are housed indoors OR in a suitably IP rated enclosure.

Installation

Check that the mounting surface is suitable for the installation of this fitting.

Step 1 Using two suitable fixings, screw the fitting to the surface.

Step 2 Make mains connections to SELV LED driver and extra low voltage connections to the fitting.

After opening the sealed portion of the luminaire for any reason, MSL recommends running the fitting for 15 minutes with the lid open to expel moisture before closing it up. This will prevent condensation on the lens and protect the fitting from corrosion.

WARNING: Do not look at exposed LED lamps in operation. Eye injury can result.

Cleaning:

Fully isolate the fitting and allow to cool.

Clean the fitting with a slightly damp lint free cloth from a mild solution of soap and water. The fitting must be completely dry before reconnecting power.

Incompatible or abrasive chemicals can damage the fitting, contact MSL for advice if required.

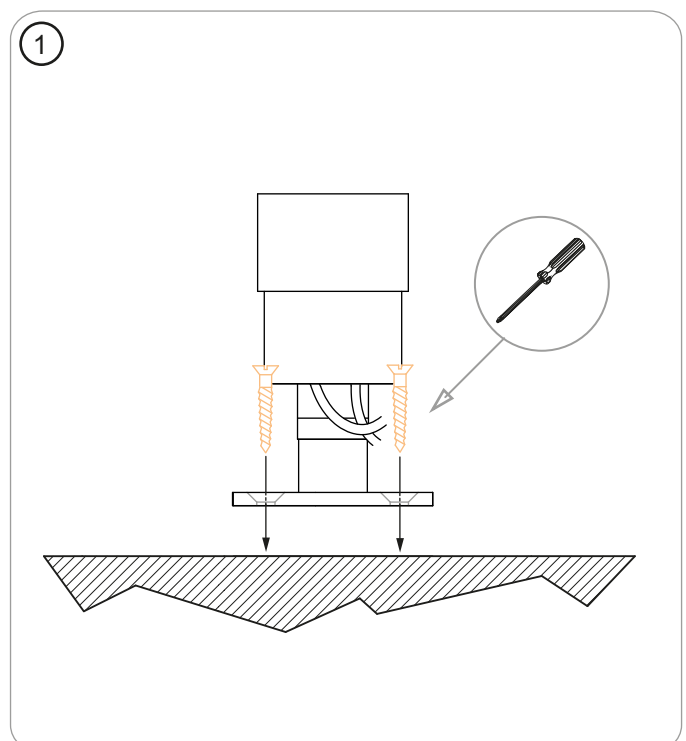

ADJUSTMENT

Using the supplied 1.5mm Allen key, the tilt and pan can be unlocked and adjusted.

When locking take care not to overtighten, the fixings should be tightened until the fitting is just locked.

OPTIC CHANGE

To change the optic, unscrew the front bezel and remove the black optic holder.

The optic can be pushed out of its holder and replaced by another 20mm XPE optic from Mike Stoane Lighting.

To replace the optic place the new optic into the optic holder. Replace the optic holder in the tadpole body being sure to line the pins of the holder up with the slots on the LEDs circuit board.

Once in place fully tighten the bezel to close the fitting.

