

## P20LWW – Plaster-in 20 Linear Wall Wash

### Installation Instructions

Page 1

- **Please read entire instruction before beginning installation.**
- Keep all instructions for future reference.
- Any modification of the luminaire voids any and all written or implied warranty.
- Manufacturer accepts no responsibility for damage to persons or property arising through installation or use.

 • Risk of Fire/Electric Shock. Disconnect power at fuse or circuit breaker before installing. Failure to do so may result in personal serious injury.

 • Risk of Fire/Electric Shock. Fixture must be installed in accordance with local and/or National Electrical Code.

 • Installation and maintenance should only be performed by a qualified electrician.

### Unpacking Instructions

Before you begin, please un-pack, identify and inspect all components. Per the TERMS AND CONDITIONS OF SALE, please contact Inter-lux if any items are found to be damaged or missing.

Fixtures will be packaged in multi-pack boxes or individually for smaller quantities. Individual fixtures are identified similar to:

<u>Fixture</u>	<u>Description</u>
SM20LDL-S-46800-M-835-OD	SM20LDL Housing Assembly, Straight, 46.800", Mid Power, 80 CRI, 3500K, Opal Diffuser



In addition to box labels, each fixture will be individually labeled on the back as shown:

The following page shows all possible parts for the P20LWW. Not all items are needed for every installation. Refer to your specific packing list to identify parts.

Once all items are identified and sorted, proceed to installation steps.

**Technical Support Line (410) 381-1497**

# P20LWW – Plaster-in 20 Linear Wall Wash

## Installation Instructions

Page 2

### Parts Identification (not to scale)

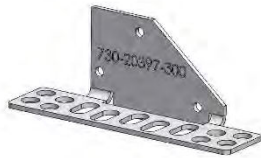

Right Endcap  
730-20397-300

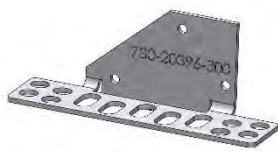

Left Endcap  
730-20396-300



Joiner  
820-10039-300



Clip  
730-20393-200

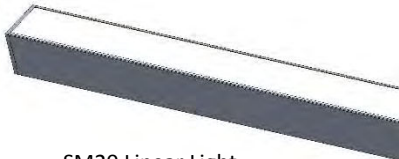

SM20 Linear Light

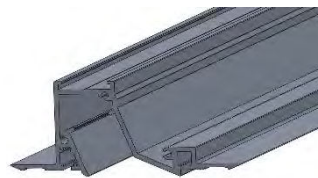

Wall Wash Housing / Extrusion  
710-10347-300



SM20 Endcap  
720-10001-304

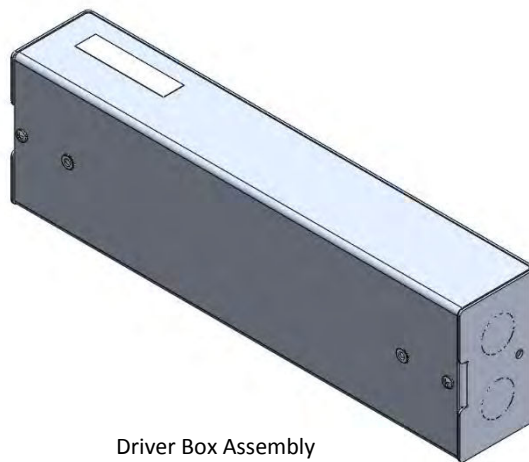

Driver Box Assembly

## P20LWW – Plaster-in 20 Linear Wall Wash

### Installation Instructions

Page 3

#### Installation Instructions

Locate and review any construction plans and the Interlux Record Drawings for all fixture runs.

**NOTE:** It is recommended to locate and lay out all components for each fixture “run”. A fixture run typically consists of endcaps, joiners, lengths of housings, lengths of SM20 lights and driver boxes.

Housing and light fixture lengths may be similar in appearance but slightly different in length. Driver boxes may be similar in appearance but contain different power supplies. Be sure to identify all the correct lengths and drivers for each fixture run.

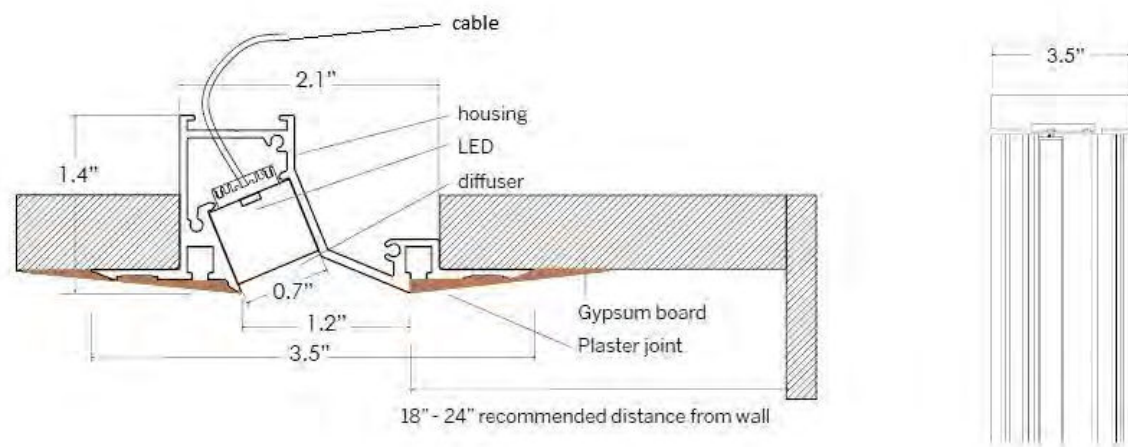

Please review the above dimensional sketch. This sketch details the recommended distance from the wall, positioning and the recommended cut-out size. Sketch also indicates how the housing will need to be drilled and routing for power cables.

#### Install Driver Box



The driver box must be mounted and wired in accordance with the National Electric Code (NEC) as well as applicable State and Local codes and jurisdictions.



**WARNING: DO NOT HOT-PLUG.** Power must be off until all connections are made. LED damage will occur if drivers are powered/energized while making connections.

1. Mount the driver boxes per the construction plans. Typically, this must be in an accessible location.
2. Wire the high voltage power feeds.
3. Wire the dimming or control leads if applicable.
4. The output leads will be connected later, after fixtures are installed.

# P20LWW – Plaster-in 20 Linear Wall Wash

## Installation Instructions

Page 4

### Mounting Housing

The housing must be mounted securely to avoid cracking in the plaster and painted finish.

It is recommended that backing (typically wood) be installed behind the perimeter of the fixture. The housing should be secured to the backing. In lieu of backing, the housing can be securely mounted to wall studs and/or anchors as needed.

The housing is supplied without mounting holes. These will need to be drilled to align with wood backing, studs or anchors as needed. Use #6 drywall screws.

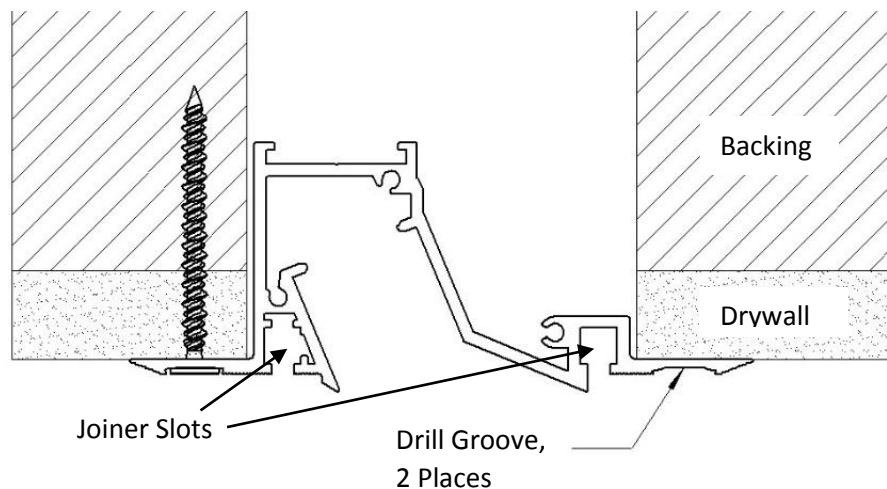

### Install Fixture Run (Housings)

1. Mark and cut gypsum/plaster board/drywall for desired location of the housing. The cutout dimensions should be 2.1" wide x length of fixture housings + ¼" clearance.
2. Starting with first housing, install an endcap, using #4 screws provided with Endcap Kit.
3. Mark and drill mounting holes, in the housing, in desired locations. Recommend a maximum of 24 inch centers. An alignment groove is provided to center the hole in the slots.
4. Mark and drill a hole in back of housing for the power feed cable route to the Driver Box.
5. Install joiners into other end of housing. Joiner should be inserted about halfway into housing. Secure in place by tightening M3 setscrews.
6. Mark and drill mounting holes in the next housing section.
7. Insert joiners into far end of the next housing section.
8. Install the next housing section. Align joiners from the first section and slide together until butted against first housing section. Install mounting screws and tighten remaining joiner setscrews.
9. Mark and drill the next hole in back of housing for next power feed cable.
10. Repeat steps 6-9 until you reach final housing section of the fixture run.
11. Install an endcap in the final section.
12. Mount the final housing section.

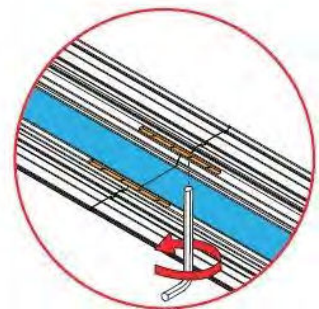

## P20LWW – Plaster-in 20 Linear Wall Wash

### Installation Instructions

Page 5

#### Finishing

13. Plaster over the housing flanges and smooth to finish. Refer to the previous dimensional sketch which details the intended plaster joint. Take care not to get plaster into the light opening.
14. Sand, paint, etc. the plaster as any normal wall joint. Take care not to get paint or construction materials on the light opening.

#### Install Fixture Run (SM20 Lights)

15. Install an endcap and screw into the first SM20 Linear Light.
16. Install clips into the SM20 Linear Lights. Use a clip at each end for fixtures up to 48 inch long. Use a third clip in the center, for fixtures over 48 inch long.



17. Route the power cable on the first SM20 Linear Light thru the first drilled hole in the housing and snap the Light into place in the housing. Light should be within about 1/8" clearance from the end of the housing.
18. Make connections in the Driver Box.
19. Route the power cable thru the next drilled hole and snap into place.
20. Repeat steps until all SM20 Linear Lights are installed. Final section should have about 1/8" clearance from the end of the housing.
21. Energize and test for proper operation.

**Technical Support Line (410) 381-1497**